

**Argentina**

Festo S.A.  
Edison 2392  
(1640) Martínez  
Prov. Buenos Aires  
Ventas y Asistencia técnica  
0810-555-FESTO (33786)  
ventas@ar.festo.com  
Tel. 0810-444-3127, Fax +54 (011) 47 17 82 82  
E-mail: info\_ar@festo.com

**Australia**

Festo Pty. Ltd.  
Head Office (Melbourne)  
179-187 Browns Road  
P.O. Box 261  
Noble Park Vic. 3174  
Tel. +61 (0)3 97 95 95 55,  
Fax +61 (0)3 97 95 97 87  
E-mail: info\_au@festo.com

**Austria**

Festo Gesellschaft m.B.H.  
Linzer Straße 227  
1140 Wien  
Tel. +43 (0)1 910 75-0, Fax +43 (0)1 910 75-250  
E-mail: automation@festo.at

**Belarus**

IP Festo  
Masherov avenue, 78  
220035 Minsk  
Tel. +375 (0)17 204 85 58,  
Fax +375 (0)17 204 85 59  
E-mail: info\_by@festo.com

**Belgium**

Festo Belgium sa  
Rue Colonel Bourg 101  
1030 Brussel  
Tel. +32 (0)2 702 32 11, Fax +32 (0)2 702 32 09  
E-mail: info\_be@festo.com

**Belgium**

Festo Belgium nv  
Kolonel Bourgstraat 101  
1030 Bruxelles  
Tel. +32 (0)2 702 32 11, Fax +32 (0)2 702 32 09  
E-mail: info\_be@festo.com

**Brazil**

Festo Brasil Ltda  
Rua Guisepe Crespi, 76  
Jd. Santa Emília  
04183-080 São Paulo / SP-Brasil  
vendas@br.festo.com  
Tel. +55 (11) 5013-1600,  
Fax +55 (11) 5013-1801  
E-mail: linhadireta@br.festo.com

**Bulgaria**

Festo EOOD  
1592 Sofia  
Bul. Christophor Kolumb 9  
Tel. +359 (0)2 960 07 12,  
Fax +359 (0)2 960 07 13  
E-mail: info\_bg@festo.com

**Canada**

Festo Didactic Ltée/Ltd  
675, Rue du Carbone  
Québec, Québec, G2N 2K7  
Tel. +1 (418) 849-1000  
Fax +1 (418) 849-1666  
E-mail: services.didactic@festo.com

**Chile**

Festo S.A.  
Avenida Américo Vespucio, 760  
Pudahuel  
Santiago  
Tel. +56 (2) 690 28 01, Fax +56 2 690 28 60  
E-mail: info.chile@cl.festo.com

**China**

Festo (China) Ltd.  
1156 Yunqiao Road,  
Jinqiao Export Processing Zone,  
Pudong,  
Shanghai 201206  
Tel. +86 21 60 81 51 00, Fax +86 21 58 54 03 00  
E-mail: info\_cn@cn.festo.com

**Colombia**

Festo Ltda  
Vereda la Punta Autopista MedellínKm.6.3 (Costado)  
Tenjo, Cundinamarca  
Tel. +57(1) 865 77 29, Fax +57(1) 865 77 94  
E-mail: mercadeo@co.festo.com

**Croatia**

Festo d.o.o.  
Nova Cesta 181  
10000 Zagreb  
Tel. +385 (0)1 619 19 69,  
Fax +385 (0)1 619 18 18  
E-mail: info\_hr@festo.com

**Czech Republic**

Festo, s.r.o.  
Modřanská 543/76  
147 00 Praha 4  
Tel. +420 261 09 96 11, Fax +420 241 77 33 84  
E-mail: info\_cz@festo.com

**Denmark**

Festo A/S  
Islevdalvej 180  
2610 Rødovre  
Tel. +45 70 21 10 90, Fax +45 44 88 81 10  
E-mail: info\_dk@festo.com

**Estonia**

Festo OY AB Eesti Filiaal  
A.H. Tammsaare tee 118B  
12918 Tallinn  
Tel. +372 666 1560, Fax +372 666 15 6  
E-mail: info\_ee@festo.com

**Finland**

Festo Oy  
Mäkituvantie 9  
PL 86  
01511 Vantaa  
Tel. +358 (09) 87 06 51,  
Fax +358 (09) 87 06 52 00  
E-mail: info\_fi@festo.com

**France**

Festo Eurl  
ZA des Maisons Rouges  
8 rue du clos sainte Catherine  
94360 Bry-sur-Marne  
Tel. +33 (0) 820 20 46 40 (numéro indigo),  
Fax +33 (0) 820 20 46 41  
E-mail: info\_fr@festo.com

**Germany**

Festo Didactic GmbH & Co. KG  
Reichbergstr. 3  
73770 Denkendorf  
Germany  
Tel. +49 (0)711 346 70,  
Fax +49 (0)711 34 75 48 85 00  
E-mail: did@de.festo.com

**Germany**

Festo AG & Co. KG  
Postfach  
73726 Esslingen  
Ruiter Straße 82  
73734 Esslingen  
Tel. +49 (0) 711 347 0, Fax +49 (0) 711 347 2628  
E-mail: info\_de@festo.com

**Greece**

Festo Ltd.  
92, Tatoi Ave.  
P.C. 144 52 Metamorfosi  
Tel. +30 210 341 29 00 - 4,  
Fax +30 210 341 29 05  
E-mail: info\_gr@festo.com

**Hong Kong**

Festo Ltd.  
6/F New Timely Factory Building,  
497 Castle Peak Road,  
Kowloon, Hong Kong  
Tel. +852 27 43 83 79, Fax +852 27 86 21 73  
E-mail: info\_hk@festo.com

**Hungary**

Festo Kft.  
Csillaghegyi út 32-34.  
1037 Budapest  
Hotline +36 1 436 51 00  
Tel. +36 1 436 51 11, Fax +36 1 436 51 01  
E-mail: info\_hu@festo.com

**India**

Festo Controls Private Ltd.  
Festo Controls Pvt. Ltd.  
35/3, Shamanna Garden  
Bannerghatta Road  
Bangalore 560 030  
Tel. +91 (0)1800 425 0036,  
Fax +91 (0)1800 121 0036  
E-mail: sales\_in@festo.com

**Indonesia**

PT. Festo  
Jl. Tekno V Blok A/1 Sektor XI  
Kawasan Industri BSD  
Serpong -Tangerang 15314  
Banten - Indonesia  
Tel. +62 (0) 21 27 50 79 00,  
Fax +62 (0) 21 27 50 79 98  
E-mail: sales\_id@festo.com

**Iran**

Festo Pneumatic S.K.  
# 2, 6th street, 16th avenue,  
Km 8, Special Karaj Road  
P.O.Box 15815-1485  
Teheran 138993761  
Tel. +98 (0)21 44 52 24 08,  
Fax +98 (0)21 44 52 24 08  
E-mail: Mailroom@festo.ir

**Ireland**

Festo Limited  
Unit 5 Sandlyford Park  
Sandlyford Industrial Estate  
Dublin 18  
Tel. +353 (0)1 295 49 55,  
Fax +353 (0)1 295 56 80  
E-mail: info\_ie@festo.com

**Israel**

Festo Pneumatic Israel Ltd.  
P.O. Box 1076  
Ha'atzma'ut Road 48  
Yehud 56100  
Tel. +972 (0)3 632 22 66,  
Fax +972 (0)3 632 22 77  
E-mail: info\_il@festo.com

**Italy**

Festo SpA  
Via Enrico Fermi 36/38  
20090 Assago (MI)  
Tel. +39 02 45 78 81, Fax +39 02 488 06 20  
E-mail: info\_it@festo.com

**Japan**

Festo K.K.  
1-26-10 Hayabuchi  
Tsuzuki-ku  
Yokohama 224-0025  
Tel. +81 (0)45 593 5610 / -5611,  
Fax +81 (0)45 593 5678  
E-mail: info\_jp@festo.com

**Korea South**

Festo Korea Co., Ltd.  
Gasan Digital 1-ro  
Geumcheon-gu  
Seoul #153-803  
Tel. +82 1666 0202, Fax +82 (0)2 864 70 40  
E-mail: sales\_kr@kr.festo.com

**Latvia**

Festo SIA  
Gunāra Astras 1C  
LV-1084, Rīga  
Tel. +371 67 57 78 64, Fax +371 67 57 79 46  
E-mail: info\_lv@festo.com

**Lithuania**

Festo, UAB  
Partizanų 63M  
50306 Kaunas  
Lietuva  
Tel. +370 (8) 7 32 13 14, Fax +370 (8) 7 32 13 15  
E-mail: info\_lt@festo.com

**Malaysia**

Festo Sdn. Berhad  
10 Persiaran Industri  
Bandar Sri Damansara  
Wilayah Persekutuan  
52200 Kuala Lumpur  
Tel. +60 (0)3 62 86 80 00,  
Fax +60 (0)3 62 75 64 11  
E-mail: info\_my@festo.com

**Mexico**

Festo Pneumatic, S.A.  
Av. Ceylán 3,  
Col. Tequesquihuac  
54020 Tlalnepanla  
Estado de México  
Tel. +52 (0)155 53 21 66 00,  
Fax +52 (0)155 53 21 66 55  
E-mail: festo.mexico@mx.festo.com

**Netherlands**

Festo B.V.  
Schieweg 62  
2627 AN  
Tel. +31 (0)15 251 88 99,  
Fax +31 (0)15 251 88 67  
E-mail: sales@festo.nl

**New Zealand**

Festo Ltd.  
20 Fisher Crescent  
Mount Wellington  
Auckland  
Tel. +64 (0)9 574 10 94, Fax +64 (0)9 574 10 99  
E-mail: info\_nz@festo.com

**Nigeria**

Festo Automation Ltd.  
Motorways Centre, Ground Floor, Block C  
Alausa, Ikeja,  
Lagos  
Tel. +234 (0)1 794 78 20,  
Fax +234 (0)1 555 78 94  
E-mail: info\_ng@festo.com

**Norway**

Festo AS  
Ole Deviks vei 2  
0666 Oslo  
Tel. +47 22 72 89 50, Fax +47 22 72 89 51  
E-mail: info\_no@festo.com

**Peru**

Festo S.R.L.  
Amador Merino Reyna 480  
San Isidro  
Lima  
Tel. +51 (1) 219 69 60, Fax +51 (1) 219 69 71  
E-mail: festo.peru@pe.festo.com

**Philippines**

Festo Inc.  
KM 18, West Service Road  
South Super Highway  
1700 Paranaque City  
Metro Manila  
Tel. +63 (2) 77 66 888, Fax +63 (2) 82 34 220/21  
E-mail: info\_ph@festo.com

**Poland**

Festo Sp. z o.o.  
Janki k/Warszawy  
ul. Mszczonowska 7  
05090 Raszyn  
Tel. +48 (0)22 711 41 00,  
Fax +48 (0)22 711 41 02  
E-mail: info\_pl@festo.com

**Portugal**

Festo - Automação, Unipessoal, Lda.  
Rua Manuel Pinto De Azevedo, 567  
Apartado 8013  
P-4109601 Porto  
Contact Center: 707 20 20 43  
Tel. +351 22 615 61 50, Fax +351 22 615 61 89  
E-mail: info\_pt@festo.com

**Romania**

Festo S.R.L.  
St. Constantin 17  
010217 Bucuresti  
Tel. +40(0)21 403 95 00,  
Fax +40 (0)21 310 24 09  
E-mail: info\_ro@festo.com

**Russia**

OOO Festo-RF  
Michurinskiy prosp., 49  
119607 Moscow  
Tel. +7 495 737 34 00, Fax +7 495 737 34 01  
E-mail: info\_ru@festo.com

**Singapore**

Festo Pte. Ltd.  
6 Kian Teck Way  
Singapore 628754  
Tel. +65 62 64 01 52, Fax +65 62 61 10 26  
E-mail: info\_sg@festo.com

**Slovakia**

Festo spol. s r.o.  
Gavilovicová ul. 1  
83103 Bratislava 3  
Tel. +421 (0)2 49 10 49 10,  
Fax +421 (0)2 49 10 49 11  
E-mail: info\_sk@festo.com

**Festo worldwide****Slovenia**

Festo d.o.o. Ljubljana  
IC Trzin, Blatnica 8  
1236 Trzin  
Tel. +386 (0)1 530 21 00,  
Fax +386 (0)1 530 21 25  
E-mail: info\_si@festo.com

**South Africa**

Festo (Pty) Ltd.  
22-26 Electron Avenue  
P.O. Box 255  
Isando 1600  
Tel. +27 (0)11 971 55 00,  
Fax +27 (0)11 974 21 57  
E-mail: info\_za@festo.com

**Spain**

Festo Pneumatic, S.A.U.  
Avenida Granvia, 159  
Distrito Económico Granvia L'H  
08908 Hospitalet de Llobregat  
Barcelona  
Tel. +34 901243660, Fax +34 902243660  
E-mail: info\_es@festo.com

**Sweden**

Festo AB  
Stilmansgatan 1  
Box 21038  
200 21 Malmö  
Tel. +46 (0)20 38 38 40, Fax +46 (0)40 38 38 10  
E-mail: order@festo.se

**Switzerland**

Festo AG  
Moosmattstrasse 24  
8953 Dietikon ZH  
Tel. +41 (0)44 744 55 44,  
Fax +41 (0)44 744 55 00  
E-mail: info\_ch@festo.com

**Taiwan**

Festo Co., Ltd.  
Head Office  
9, Kung 8th Road  
Linkou 2nd Industrial Zone  
Linkou Dist., New Taipei City  
24450 Taiwan, R.O.C.  
Tel. +886 (0)2 26 01-92 81,  
Fax +886 (0)2 26 01 92 86-7  
E-mail: festotw@tw.festo.com

**Thailand**

Festo Ltd.  
Viranuvat Building, 6th - 7th Floor.  
1250 Bangna - Trad Road (Soi 34)  
Bangna, Bangkok 10260  
Tel. 1-800-290-477,+66-2785-3700,  
Fax 1-800-290-478  
E-mail: info\_th@festo.com

**Turkey**

Festo San. ve Tic. A.S.  
Istanbul Anadolu Yakasi Organize Sanayi Bolgesi  
Aydinli Mah. TEM Yan Yol Cad. No:16  
34953 Tuzla - Istanbul/TR  
Tel. +90 (0)216 585 00 85,  
Fax +90 (0)216 585 00 50  
E-mail: info\_tr@festo.com

**Ukraine**

DP Festo  
ul. Borissoglebskaya,11  
04070, Kiev  
Tel. +380 (0)44 233 6451,  
Fax +380 (0)44 463 70 96  
E-mail: orders\_ua@festo.com

**United Kingdom**

Festo Limited  
Applied Automation Centre  
Caswell Road  
Brackmills Trading Estate  
Northampton NN4 7PY  
Tel. +44 (0)1604 / 66 70 00,  
Fax +44 (0)1604 / 66 70 01  
E-mail: info\_gb@festo.com

**United States**

Festo Didactic Inc.  
607 Industrial Way West  
Eatontown, NJ 07724  
Tel. +1 (732) 938-2000  
Fax +1 (732) 774-8573  
E-mail: services.didactic@festo.com

**Venezuela**

Festo C.A.  
Av. 23 esquina con calle 71  
N° 22-62, Edif. Festo.  
Sector Faraiso  
Maracaibo - Venezuela  
Tel. +58 (261) 759 11 20/759 41 20/759 44 38,  
Fax +58 (261) 759 04 55  
E-mail: festo@festo.com.ve

**Vietnam**

Festo Co Ltd  
(Cong Ty TNHH FESTO)  
No. 1515 - 1516 Van Dai Dong Street  
Ward An Phu, District 2  
Ho Chi Minh City  
Tel. +84 (8) 62 81 44 53 - 4454,  
Fax +84 (8) 62 81 44 42  
E-mail: info\_vn@festo.com

# Three-Phase AC Power Circuits

**FESTO**

Student Manual

Three-Phase AC Power Circuits

**FESTO**

Electricity and New Energy

LabVolt Series

Student Manual

Festo Didactic  
en  
86360-00

**Electricity and New Energy**

# **Three-Phase AC Power Circuits**

**Student Manual**

86360-00

Order no.: 86360-00

Revision level: 01/2015

By the staff of Festo Didactic

© Festo Didactic Ltée/Ltd, Quebec, Canada 2010

Internet: [www.festo-didactic.com](http://www.festo-didactic.com)

e-mail: [did@de.festo.com](mailto:did@de.festo.com)

Printed in Canada

All rights reserved

ISBN 978-2-89640-446-9 (Printed version)

ISBN 978-2-89640-728-6 (CD-ROM)

Legal Deposit – Bibliothèque et Archives nationales du Québec, 2010

Legal Deposit – Library and Archives Canada, 2010

The purchaser shall receive a single right of use which is non-exclusive, non-time-limited and limited geographically to use at the purchaser's site/location as follows.

The purchaser shall be entitled to use the work to train his/her staff at the purchaser's site/location and shall also be entitled to use parts of the copyright material as the basis for the production of his/her own training documentation for the training of his/her staff at the purchaser's site/location with acknowledgement of source and to make copies for this purpose. In the case of schools/technical colleges and training centers, and universities, the right of use shall also include use by school and college students and trainees at the purchaser's site/location for teaching purposes.

The right of use shall in all cases exclude the right to publish the copyright material or to make this available for use on intranet, Internet and LMS platforms and databases such as Moodle, which allow access by a wide variety of users, including those outside of the purchaser's site/location.

Entitlement to other rights relating to reproductions, copies, adaptations, translations, microfilming and transfer to and storage and processing in electronic systems, no matter whether in whole or in part, shall require the prior consent of Festo Didactic GmbH & Co. KG.

















Information in this document is subject to change without notice and does not represent a commitment on the part of Festo Didactic. The Festo materials described in this document are furnished under a license agreement or a nondisclosure agreement.

Festo Didactic recognizes product names as trademarks or registered trademarks of their respective holders.

All other trademarks are the property of their respective owners. Other trademarks and trade names may be used in this document to refer to either the entity claiming the marks and names or their products. Festo Didactic disclaims any proprietary interest in trademarks and trade names other than its own.









# Safety and Common Symbols

The following safety and common symbols may be used in this manual and on the equipment:

Symbol	Description
	<b>DANGER</b> indicates a hazard with a high level of risk which, if not avoided, will result in death or serious injury.
	<b>WARNING</b> indicates a hazard with a medium level of risk which, if not avoided, could result in death or serious injury.
	<b>CAUTION</b> indicates a hazard with a low level of risk which, if not avoided, could result in minor or moderate injury.
	<b>CAUTION</b> used without the <i>Caution, risk of danger</i> sign  , indicates a hazard with a potentially hazardous situation which, if not avoided, may result in property damage.
	Caution, risk of electric shock
	Caution, hot surface
	Caution, risk of danger
	Caution, lifting hazard
	Caution, hand entanglement hazard
	Notice, non-ionizing radiation
	Direct current
	Alternating current
	Both direct and alternating current
	Three-phase alternating current
	Earth (ground) terminal



# Safety and Common Symbols

Symbol	Description
	Protective conductor terminal
	Frame or chassis terminal
	Equipotentiality
	On (supply)
	Off (supply)
	Equipment protected throughout by double insulation or reinforced insulation
	In position of a bi-stable push control
	Out position of a bi-stable push control

# Table of Contents

Preface .....	VII
About This Manual .....	IX
<b>Exercise 1 Three-Phase Circuits .....</b>	<b>1</b>
DISCUSSION .....	1
Introduction to polyphase systems and three-phase circuits .....	1
Wye and delta configurations .....	3
Distinction between line and phase voltages, and line and phase currents .....	4
Power in balanced three-phase circuits .....	6
PROCEDURE .....	6
Setup and connections .....	7
Phase and line voltage measurements in the Power Supply .....	8
Voltage, current, and power measurements in a wye-connected circuit .....	10
Voltage, current, and power measurements in a delta-connected circuit .....	14
<b>Exercise 2 Three-Phase Power Measurement.....</b>	<b>19</b>
DISCUSSION .....	19
Calculating power in balanced three-phase circuits .....	19
Power measurements in single-phase circuits .....	20
Measuring the total power in four-wire, three-phase circuits .....	21
Measuring the total power in three-wire, three-phase circuits (two-wattmeter method) .....	22
Measuring the total power in four-wire, three-phase circuits using the two-wattmeter method .....	25
PROCEDURE .....	26
Setup and connections .....	26
Measuring the total power in four-wire, three-phase circuits .....	28
Measuring the total power in three-wire, three-phase circuits (wye configuration) .....	31
Measuring the total power in three-wire, three-phase circuits (delta configuration) .....	33
Measuring the total power in four-wire, three-phase circuits using the two-wattmeter method .....	36

# Table of Contents

<b>Exercise 3</b>	<b>Phase Sequence</b> .....	<b>41</b>
	DISCUSSION .....	41
	Phase sequence fundamentals .....	41
	Determining the phase sequence of a three-phase power system using an oscilloscope .....	44
	Connecting an oscilloscope to a three-phase power system.....	46
	PROCEDURE.....	47
	Setup and connections .....	47
	Determining the phase sequence of the three-phase ac power source .....	49
<b>Appendix A</b>	<b>Equipment Utilization Chart</b> .....	<b>53</b>
<b>Appendix B</b>	<b>Glossary of New Terms</b> .....	<b>55</b>
<b>Appendix C</b>	<b>Impedance Table for the Load Modules</b> .....	<b>57</b>
<b>Appendix D</b>	<b>Circuit Diagram Symbols</b> .....	<b>59</b>
	Index of New Terms .....	65
	Bibliography .....	67

# Preface

The production of energy using renewable natural resources such as wind, sunlight, rain, tides, geothermal heat, etc., has gained much importance in recent years as it is an effective means of reducing greenhouse gas (GHG) emissions. The need for innovative technologies to make the grid smarter has recently emerged as a major trend, as the increase in electrical power demand observed worldwide makes it harder for the actual grid in many countries to keep up with demand. Furthermore, electric vehicles (from bicycles to cars) are developed and marketed with more and more success in many countries all over the world.

To answer the increasingly diversified needs for training in the wide field of electrical energy, the Electric Power Technology Training Program was developed as a modular study program for technical institutes, colleges, and universities. The program is shown below as a flow chart, with each box in the flow chart representing a course.

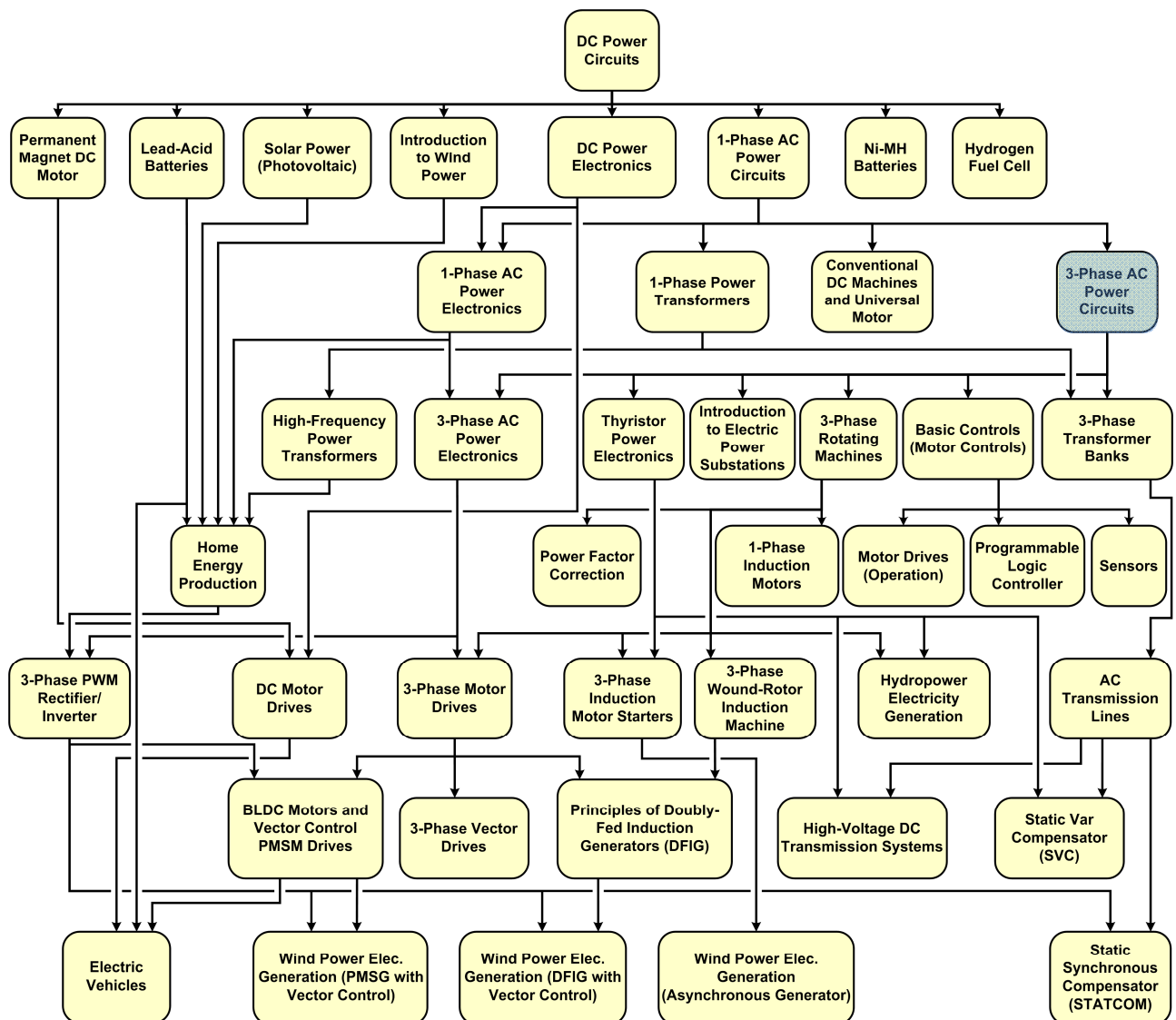

The Electric Power Technology Training Program.

# Preface

The program starts with a variety of courses providing in-depth coverage of basic topics related to the field of electrical energy such as ac and dc power circuits, power transformers, rotating machines, ac power transmission lines, and power electronics. The program then builds on the knowledge gained by the student through these basic courses to provide training in more advanced subjects such as home energy production from renewable resources (wind and sunlight), large-scale electricity production from hydropower, large-scale electricity production from wind power (doubly-fed induction generator [DFIG], synchronous generator, and asynchronous generator technologies), smart-grid technologies (SVC, STATCOM, HVDC transmission, etc.), storage of electrical energy in batteries, and drive systems for small electric vehicles and cars.

Do you have suggestions or criticism regarding this manual?

If so, send us an e-mail at [did@de.festo.com](mailto:did@de.festo.com).

The authors and Festo Didactic look forward to your comments.

# About This Manual

Three-phase ac power is one of the most common forms of electric power distribution worldwide. Many countries use three-phase ac power for power distribution since it is simpler, cheaper, and more efficient than single-phase ac power. Although most homes and small buildings are wired for single-phase ac power, they tap power off basic three-phase power distribution lines.

Three-phase ac power has a number of advantages over other means of power distribution. The main advantage is that, since the phase currents of three-phase power cancel each other out, it is possible to reduce the size of the neutral wire or to eliminate it altogether. This means that three-phase power lines can deliver more power for a given equipment weight and cost. Three-phase power systems also yield a more constant power transfer, which reduces the vibrations observed when motors and alternators (especially large ones) are connected to the system. Although it is possible for a polyphase power system to have more than three phases, three-phase power is the type of polyphase system having the lowest number of phases to exhibit the advantages mentioned above. Power distribution systems having a higher number of phases are for the moment simply too complex and costly to justify their common use.

This manual, *Three-Phase AC Power Circuits*, teaches the basic concepts of three-phase ac power. The student is introduced to the two basic types of three-phase circuit connections: the wye (star) and delta configurations. The student learns how to calculate phase and line voltages, phase and line currents, phase balance, etc. The student then learns how to measure power in three-phase circuits using the two-wattmeter method as well as how to determine the power factor. Finally, the student learns what the phase sequence is and how to determine the phase sequence of a three-phase power system.



**Three-phase power distribution lines.**

# About This Manual

## **Safety considerations**

Safety symbols that may be used in this manual and on the equipment are listed in the Safety Symbols table at the beginning of the manual.

Safety procedures related to the tasks that you will be asked to perform are indicated in each exercise.

Make sure that you are wearing appropriate protective equipment when performing the tasks. You should never perform a task if you have any reason to think that a manipulation could be dangerous for you or your teammates.

## **Prerequisite**

As a prerequisite to this course, you should have read the manuals titled *DC Power Circuits*, p.n. 86350 and *Single-Phase AC Power Circuits*, p.n. 86358.

## **Systems of units**

Units are expressed using the International System of Units (SI) followed by the units expressed in the U.S. customary system of units (between parentheses).



## Three-Phase Circuits

### EXERCISE OBJECTIVE

When you have completed this exercise, you will know what three-phase circuits are and how to solve balanced three-phase circuits connected in wye and delta configurations. You will also know the difference between line and phase voltages, and line and phase currents, as well as the relationship between line and phase parameter values in wye- and delta-connected three-phase circuits. You will know what the phase sequence of a three-phase circuit is. You will have learned how to calculate the active power dissipated in each phase of three-phase circuits, and how to calculate the total active power dissipated in a circuit. Finally, you will be able to use voltage and current measurements to verify the theory and calculations presented in this exercise.

### DISCUSSION OUTLINE

The Discussion of this exercise covers the following points:

- Introduction to polyphase systems and three-phase circuits
- Wye and delta configurations
- Distinction between line and phase voltages, and line and phase currents
- Power in balanced three-phase circuits

### DISCUSSION

#### Introduction to polyphase systems and three-phase circuits

A polyphase system is basically an ac system composed of a certain number of single-phase ac systems having the same frequency and operating in sequence. Each phase of a polyphase system (i.e., the phase of each single-phase ac system) is displaced from the next by a certain angular interval. In any polyphase system, the value of the angular interval between each phase depends on the number of phases in the system. This manual covers the most common type of polyphase system, the three-phase system.

Three-phase systems, also referred to as three-phase circuits, are polyphase systems that have three phases, as their name implies. They are no more complicated to solve than single-phase circuits. In the majority of cases, three-phase circuits are symmetrical and have identical impedances in each of the circuit's three branches (phases). Each branch can be treated exactly as a single-phase circuit, because a **balanced three-phase circuit** is simply a combination of three single-phase circuits. Therefore, voltage, current, and power relationships for three-phase circuits can be determined using the same basic equations and methods developed for single-phase circuits. Non-symmetrical, or unbalanced, three-phase circuits represent a special condition and their analysis is more complex. Unbalanced three-phase circuits are not covered in detail in this manual.

A three-phase ac circuit is powered by three voltage sine waves having the same frequency and magnitude and which are displaced from each other by  $120^\circ$ . The phase shift between each voltage waveform of a three-phase ac power source is

therefore  $120^\circ$  ( $360^\circ \div 3$  phases). Figure 1 shows an example of a simplified three-phase generator (alternator) producing three-phase ac power. A rotating magnetic field produced by a rotating magnet turns inside three identical coils of wire (windings) physically placed at a  $120^\circ$  angle from each other, thus producing three separate ac voltages (one per winding). Since the generator's rotating magnet turns at a fixed speed, the frequency of the ac power that is produced is constant, and the three separate voltages attain the maximal voltage value one after the other at phase intervals of  $120^\circ$ .

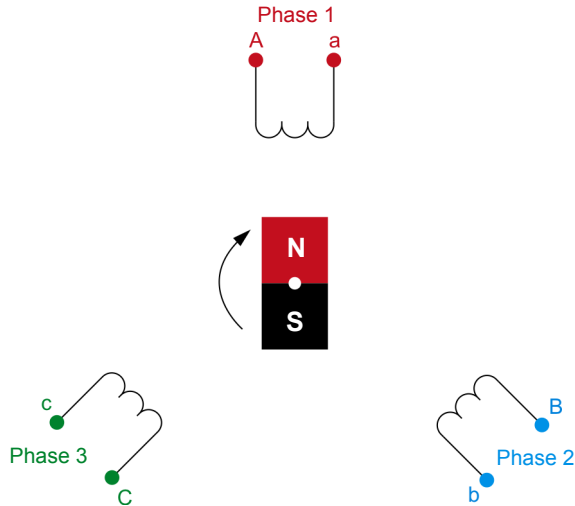
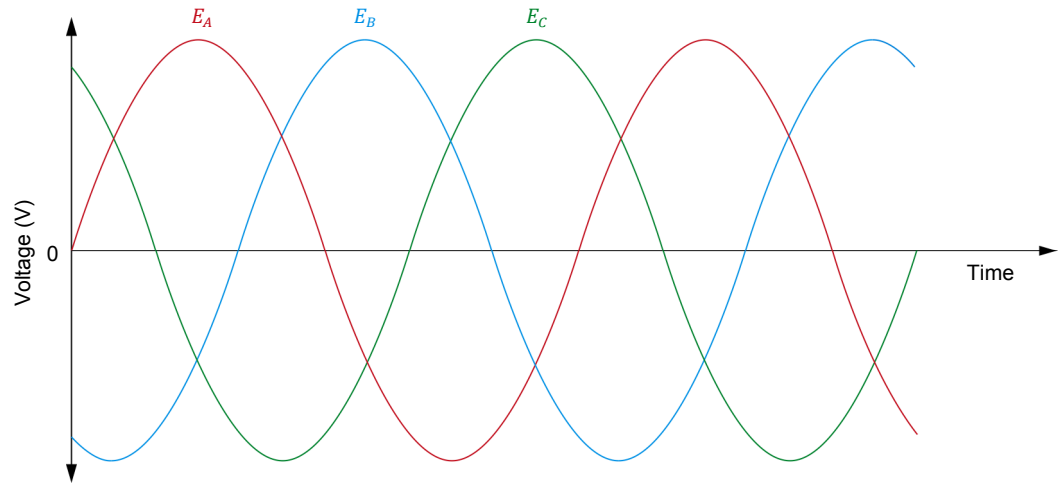

Figure 1. A simplified three-phase generator.

The **phase sequence** of the voltage waveforms of a three-phase ac power source indicates the order in which they follow each other and attain the maximal voltage value. Figure 2 shows an example of the voltage waveforms produced in a three-phase ac power source, as well as the phasor diagram related to the voltage waveforms. The voltage waveforms and voltage phasors in Figure 2 follow the phase sequence  $E_A, E_B, E_C$ , which, when written in shorthand form, is the sequence A-B-C. This phase sequence is obtained when the magnet in the three-phase generator of Figure 1 rotates clockwise.

The phase sequence of a three-phase ac power source is important because it determines the direction of rotation of any three-phase motor connected to the power source. If the phases are connected out of sequence, the motor will turn in the opposite direction, and the consequences could be serious. For example, if a three-phase motor rotating in the clockwise direction causes an elevator to go up, connecting the phase wires incorrectly to the motor would cause the elevator to go down when it is supposed to go up, and vice-versa, which could result in a serious accident.



(a) Voltage waveforms produced in a three-phase ac power source

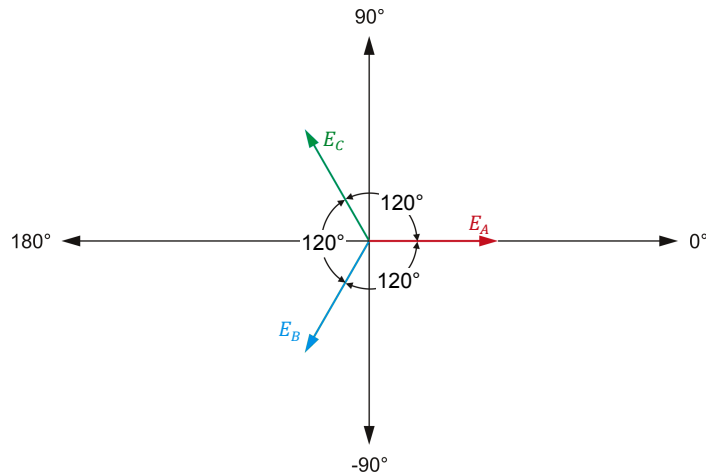

(b) Phasor diagram related to the voltage waveforms shown in (a)

Figure 2. A-B-C phase sequence of a three-phase ac power source.

### Wye and delta configurations

The windings of a three-phase ac power source (e.g., the generator in Figure 1) can be connected in either a **wye configuration**, or a **delta configuration**. The configuration names are derived from the appearance of the circuit drawings representing the configurations, i.e., the letter Y for the wye configuration and the Greek letter delta ( $\Delta$ ) for the delta configuration. The connections for each configuration are shown in Figure 3. Each type of configuration has definite electrical characteristics.

As Figure 3a shows, in a wye-connected circuit, one end of each of the three windings (or phases) of the three-phase ac power source is connected to a common point called the neutral. No current flows in the neutral because the currents flowing in the three windings (i.e., the phase currents) cancel each other out when the system is balanced. Wye connected systems typically consist of three or four wires (these wires connect to points A, B, C, and N in Figure 3a), depending on whether or not the neutral line is present.

Figure 3b shows that, in a delta-connected circuit, the three windings of the three-phase ac power source are connected one to another, forming a triangle. The three line wires are connected to the three junction points of the circuit (points A, B, and C in Figure 3b). There is no point to which a neutral wire can be connected in a three-phase delta-connected circuit. Thus, delta-connected systems are typically three-wire systems.

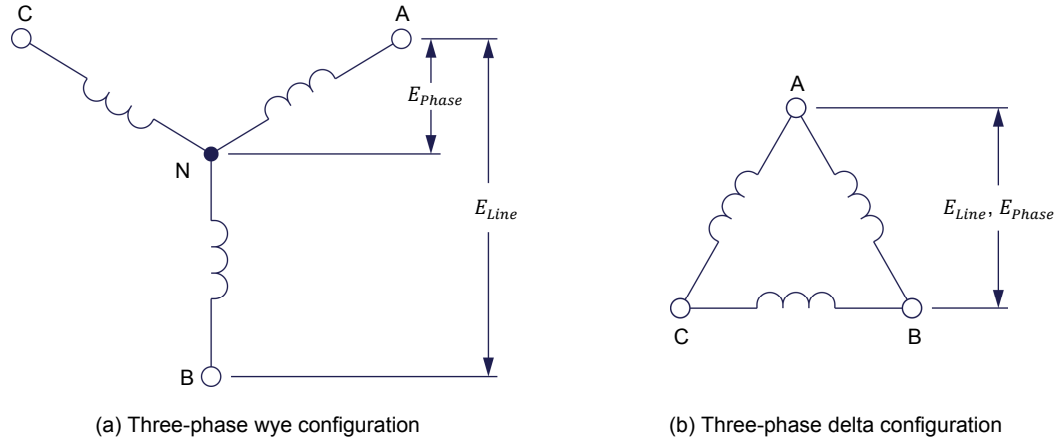
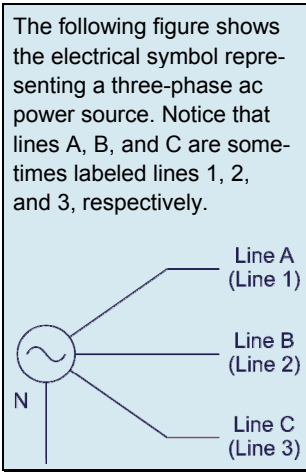

Figure 3. Types of three-phase system configurations.

### Distinction between line and phase voltages, and line and phase currents

The voltage produced by a single winding of a three-phase circuit is called the line-to-neutral voltage, or simply the **phase voltage**,  $E_{Phase}$ . In a wye-connected three-phase ac power source, the phase voltage is measured between the neutral line and any one of points A, B, and C, as shown in Figure 3a. This results in the following three distinct phase voltages:  $E_{A-N}$ ,  $E_{B-N}$ , and  $E_{C-N}$ .

The voltage between any two windings of a three-phase circuit is called the line-to-line voltage, or simply the **line voltage**  $E_{Line}$ . In a wye-connected three-phase ac power source, the line voltage is  $\sqrt{3}$  (approximately 1.73) times greater than the phase voltage (i.e.,  $E_{Line} = \sqrt{3} E_{Phase}$ ). In a delta-connected three-phase ac power source, the voltage between any two windings is the same as the voltage across the third winding of the source (i.e.,  $E_{Line} = E_{Phase}$ ), as shows Figure 3b. In both cases, this results in the following three distinct line voltages:  $E_{A-B}$ ,  $E_{B-C}$ , and  $E_{C-A}$ .



The three line wires (wires connected to points A, B, and C) and the neutral wire of a three-phase power system are usually available for connection to the load, which can be connected in either a wye configuration or a delta configuration. The two types of circuit connections are illustrated in Figure 4. Circuit analysis demonstrates that the voltage (line voltage) between any two line wires, or lines, in a wye-connected load is  $\sqrt{3}$  times greater than the voltage (phase voltage) across each load resistor. Furthermore, the **line current**  $I_{Line}$  flowing in each line of the power source is equal to the **phase current**  $I_{Phase}$  flowing in each load resistor. On the other hand, in a delta-connected load, the voltage (phase voltage) across each load resistor is equal to the line voltage of the source. Also, the line current is  $\sqrt{3}$  times greater than the current (phase current) in each load resistor. The phase current in a delta-connected load is therefore  $\sqrt{3}$  times smaller than the line current.

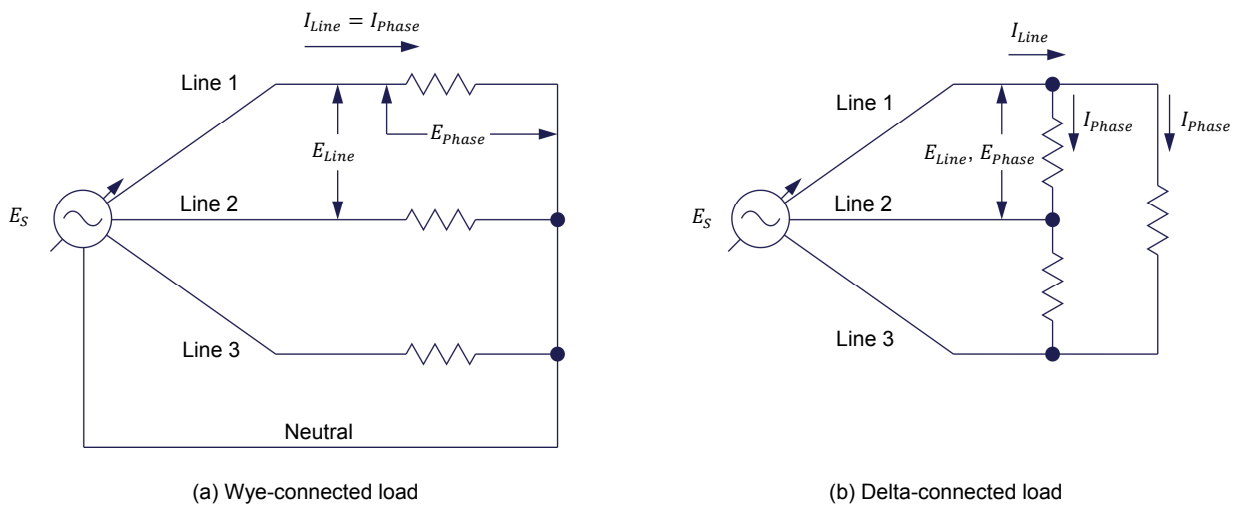

Figure 4. Types of load connections.

The relationships between the line and phase voltages and the line and phase currents simplify the analysis of balanced three-phase circuits. A shorthand way of writing these relationships is given below.

- In wye-connected circuits:

$$E_{Line} = \sqrt{3} E_{Phase} \text{ and } I_{Line} = I_{Phase}$$

- In delta-connected circuits:

$$E_{Line} = E_{Phase} \text{ and } I_{Line} = \sqrt{3} I_{Phase}$$

### Power in balanced three-phase circuits

The formulas for calculating active, reactive, and apparent power in balanced three-phase circuits are the same as those used for single-phase circuits. Based on the formula for power in a single-phase circuit, the active power dissipated in each phase of either a wye- or delta-connected load is equal to:

$$P_{Phase} = E_{Phase} \times I_{Phase} \times \cos \varphi \quad (1)$$

- where
- $P_{Phase}$  is the active power dissipated in each phase of a three-phase circuit, expressed in watts (W)
  - $E_{Phase}$  is the phase voltage across each phase of a three-phase circuit, expressed in volts (V)
  - $I_{Phase}$  is the phase current flowing in each phase of a three-phase circuit, expressed in amperes (A)
  - $\varphi$  is the angle between the phase voltage and current in each phase of a three-phase circuit, expressed in degrees (°)

Therefore, the total active power  $P_T$  dissipated in a three-phase circuit is equal to:

$$P_T = 3 \times P_{Phase} = 3 \times E_{Phase} \times I_{Phase} \times \cos \varphi \quad (2)$$

- where  $P_T$  is the total active power dissipated in a three-phase circuit, expressed in watts (W)

In purely resistive three-phase circuits, the voltage and current are in phase, which means that  $\cos \varphi$  equals 1. Therefore, the total active power  $P_T$  dissipated in purely resistive three-phase circuits is equal to:

$$P_T = 3 \times E_{Phase} \times I_{Phase}$$

The Procedure is divided into the following sections:

#### PROCEDURE OUTLINE

- Setup and connections
- Phase and line voltage measurements in the Power Supply
- Voltage, current, and power measurements in a wye-connected circuit
- Voltage, current, and power measurements in a delta-connected circuit

#### PROCEDURE



High voltages are present in this laboratory exercise. Do not make or modify any banana jack connections with the power on unless otherwise specified.

### Setup and connections

*In this section, you will set up the equipment to measure the line-to-neutral (phase) and line-to-line (line) voltages of the three-phase ac power source in the Power Supply.*

1. Refer to the Equipment Utilization Chart in Appendix A to obtain the list of equipment required to perform this exercise.

Install the required equipment in the [Workstation](#).

Make sure that the ac and dc power switches on the [Power Supply](#) are set to the **O** (off) position, then connect the [Power Supply](#) to a three-phase ac power outlet.

Connect the [Power Input](#) of the [Data Acquisition and Control Interface](#) to a 24 V ac power supply. Turn the 24 V ac power supply on.

2. Connect the USB port of the [Data Acquisition and Control Interface](#) to a USB port of the host computer.

3. Turn the host computer on, then start the [LVDAC-EMS](#) software.

In the [LVDAC-EMS Start-Up](#) window, make sure that the [Data Acquisition and Control Interface](#) is detected. Make sure that the [Computer-Based Instrumentation](#) function for the [Data Acquisition and Control Interface](#) is available. Select the network voltage and frequency that correspond to the voltage and frequency of your local ac power network, then click the [OK](#) button to close the [LVDAC EMS Start-Up](#) window.

4. In [LVDAC-EMS](#), start the [Metering](#) application. Set the meters to measure the rms values (ac) of the voltages at inputs [E1](#), [E2](#), and [E3](#) of the [Data Acquisition and Control Interface](#). Click the [Continuous Refresh](#) button to enable continuous refresh of the values indicated by the various meters in the [Metering](#) application.



5. Set up the circuit shown in Figure 5.

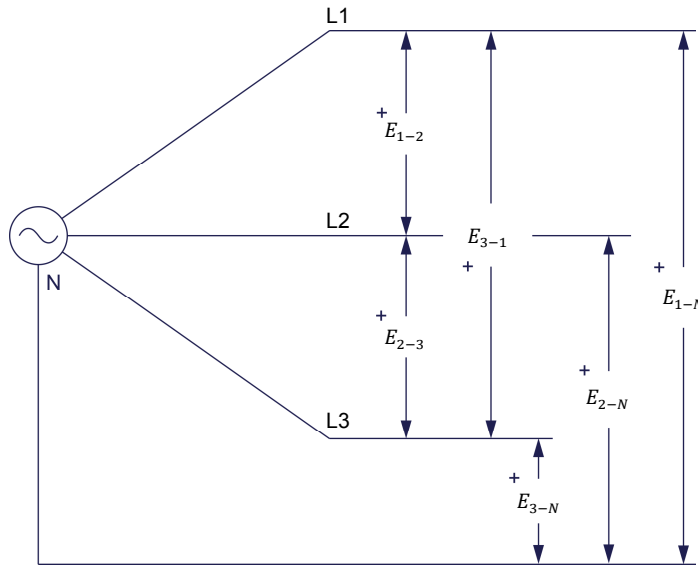

Figure 5. Line and phase voltage measurements.

Connect inputs **E1**, **E2**, and **E3** of the **Data Acquisition and Control Interface** to first measure the **Power Supply** phase voltages  $E_{1-N}$ ,  $E_{2-N}$ , and  $E_{3-N}$ , respectively. Later, you will modify the connections to inputs **E1**, **E2**, and **E3** to measure the **Power Supply** line voltages  $E_{1-2}$ ,  $E_{2-3}$ , and  $E_{3-1}$ , respectively.

### Phase and line voltage measurements in the Power Supply

*In this section, you will measure the phase voltages of the three-phase ac power source in the Power Supply, and observe the phase voltage waveforms of the three-phase ac power source using the Oscilloscope, as well as the phase voltage phasors of the three-phase ac power source using the Phasor Analyzer. You will measure the line voltages of the three-phase ac power source in the Power Supply. You will then calculate the ratio of the average line voltage to the average phase voltage and confirm that the ratio is equal to  $\sqrt{3}$ .*

6. Turn the three-phase ac power source in the **Power Supply** on.
7. Measure and record below the phase voltages of the three-phase ac power source.

$$E_{1-N} = \text{_____ V}$$

$$E_{2-N} = \text{_____ V}$$

$$E_{3-N} = \text{_____ V}$$

Determine the average value of the phase voltages.

$$\text{Average } E_{Phase} = \frac{E_{1-N} + E_{2-N} + E_{3-N}}{3} = \underline{\hspace{2cm}} \text{ V}$$

8. In LVDAC-EMS, open the [Oscilloscope](#), then make the appropriate settings in order to observe the phase voltage waveforms related to inputs [E1](#), [E2](#), and [E3](#).

Is the phase shift between each voltage sine wave of the three-phase ac power source equal to 120°?

Yes     No

9. In LVDAC-EMS, open the [Phasor Analyzer](#), then make the appropriate settings in order to observe the phase voltage phasors related to inputs [E1](#), [E2](#), and [E3](#).

Is the phase shift between each voltage phasor of the three-phase ac power source equal to 120°?

Yes     No

Turn the three-phase ac power source in the [Power Supply](#) off.

10. Modify the connections to the voltage inputs to measure the line voltages of the three-phase ac power source, then turn the three-phase ac power source in the [Power Supply](#) on. Measure and record below the line voltages of the three-phase ac power source. Turn the three-phase ac power source in the [Power Supply](#) off.

$$E_{1-2} = \underline{\hspace{2cm}} \text{ V}$$

$$E_{2-3} = \underline{\hspace{2cm}} \text{ V}$$

$$E_{3-1} = \underline{\hspace{2cm}} \text{ V}$$

Determine the average value of the line voltages.

$$\text{Average } E_{Line} = \frac{E_{1-2} + E_{2-3} + E_{3-1}}{3} = \underline{\hspace{2cm}} \text{ V}$$

11. Calculate the ratio of the average line voltage  $E_{Line}$  to the average phase voltage  $E_{Phase}$ .

$$\frac{\text{Average } E_{Line}}{\text{Average } E_{Phase}} = \underline{\hspace{2cm}}$$

12. Is the ratio of the average line voltage  $E_{Line}$  to the average phase voltage  $E_{Phase}$  calculated in the previous step approximately equal to  $1.73 (\sqrt{3})$ ?

Yes     No

### **Voltage, current, and power measurements in a wye-connected circuit**

*In this section, you will set up a wye-connected, three-phase circuit using three load resistors. You will measure the phase voltages and currents in the circuit, as well as the circuit line voltage and neutral line current. You will confirm that the load is balanced and that the ratio between the line voltage and the average phase voltage in the circuit is equal to  $\sqrt{3}$ . You will verify that the current flowing in the neutral line is equal to zero and that removing the neutral line does not affect the measured voltages and currents. You will then calculate the active power dissipated in each phase of the circuit and the total active power dissipated in the circuit using the measured phase voltages and currents. Finally, you will calculate the total active power dissipated in the circuit using the measured average phase voltage and current, and compare the two calculated total active power values.*

13. Set up the wye-connected, resistive, three-phase circuit shown in Figure 6.

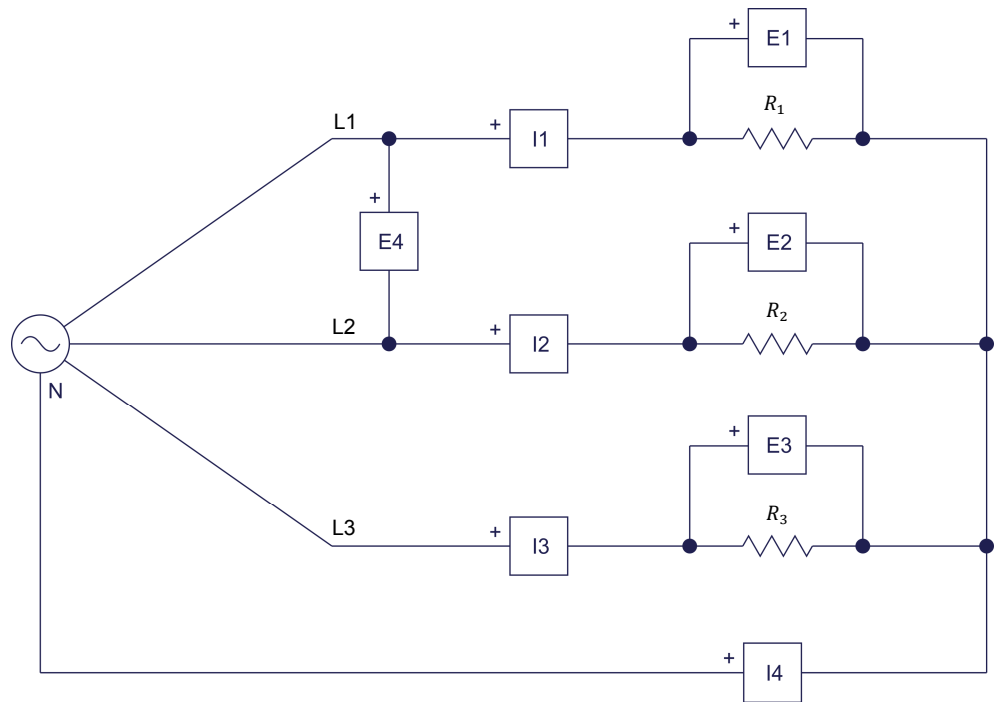

Local ac power network		$R_1$ ( $\Omega$ )	$R_2$ ( $\Omega$ )	$R_3$ ( $\Omega$ )
Voltage (V)	Frequency (Hz)			
120	60	300	300	300
220	50	1100	1100	1100
240	50	1200	1200	1200
220	60	1100	1100	1100

Figure 6. Wye-connected, three-phase circuit supplying power to a three-phase resistive load.



The values of certain components (e.g., resistors, capacitors) used in the circuits of this manual depend on your local ac power network voltage and frequency. Whenever necessary, a table below the circuit diagram indicates the value of each component for ac power network voltages of 120 V, 220 V, and 240 V, and for ac power network frequencies of 50 Hz and 60 Hz. Make sure to use the component values corresponding to your local ac power network voltage and frequency.

14. Make the necessary switch settings on the **Resistive Load** module in order to obtain the resistance values required.

Appendix C lists the switch settings required on the **Resistive Load** in order to obtain various resistance values.

15. In the **Metering** window, make the required settings in order to measure the rms values of voltages  $E_{R1}$ ,  $E_{R2}$ ,  $E_{R3}$ , and  $E_{Line}$  (inputs **E1**, **E2**, **E3**, and **E4**, respectively), and currents  $I_{R1}$ ,  $I_{R2}$ ,  $I_{R3}$ , and  $I_N$  (inputs **I1**, **I2**, **I3**, and **I4**, respectively).

16. Turn the three-phase ac power source in the **Power Supply** on.

Measure and record below the voltages and currents in the circuit of Figure 6, then turn the three-phase ac power source in the **Power Supply** off.

$$E_{R1} = \text{_____ V}$$

$$E_{R2} = \text{_____ V}$$

$$E_{R3} = \text{_____ V}$$

$$E_{Line} = \text{_____ V}$$

$$I_{R1} = \text{_____ A}$$

$$I_{R2} = \text{_____ A}$$

$$I_{R3} = \text{_____ A}$$

$$I_N = \text{_____ A}$$

17. Compare the individual load voltages  $E_{R1}$ ,  $E_{R2}$ , and  $E_{R3}$  measured in the previous step. Are they approximately equal?

Yes     No

Compare the individual load currents  $I_{R1}$ ,  $I_{R2}$ , and  $I_{R3}$  measured in the previous step. Are they approximately equal?

Yes     No

Does this mean that the three-phase load is balanced?

Yes     No

18. Calculate the average phase voltage  $E_{Phase}$  using the phase voltages recorded in step 16.

$$\text{Average } E_{Phase} = \frac{E_{R1} + E_{R2} + E_{R3}}{3} = \text{_____ V}$$

19. Is the ratio of the line voltage  $E_{Line}$  to the average phase voltage  $E_{Phase}$  approximately equal to  $\sqrt{3}$ ?

Yes     No

20. Is the current  $I_N$  flowing in the neutral line approximately equal to zero?

Yes     No

- 21.** Disconnect the neutral line, then turn the three-phase ac power source in the **Power Supply** on.

Does disconnecting the neutral line affect the measured voltages and currents indicated in the **Metering** window?

Yes     No

Is the neutral line required in a balanced, wye-connected, three-phase circuit?

Yes     No

- 22.** Turn the three-phase ac power source in the **Power Supply** off.

- 23.** Calculate the active power dissipated in each phase of the circuit and the total active power  $P_T$  dissipated in the circuit using the voltages and currents recorded in step 16.

$$P_{R1} = E_{R1} \times I_{R1} = \underline{\hspace{2cm}} \text{ W}$$

$$P_{R2} = E_{R2} \times I_{R2} = \underline{\hspace{2cm}} \text{ W}$$

$$P_{R3} = E_{R3} \times I_{R3} = \underline{\hspace{2cm}} \text{ W}$$

$$P_T = P_{R1} + P_{R2} + P_{R3} = \underline{\hspace{2cm}} \text{ W}$$

- 24.** Calculate the average phase current  $I_{Phase}$  using the phase currents recorded in step 16.

$$\text{Average } I_{Phase} = \frac{I_{R1} + I_{R2} + I_{R3}}{3} = \underline{\hspace{2cm}} \text{ A}$$

- 25.** Calculate the total active power  $P_T$  dissipated in the circuit using the average phase voltage  $E_{Phase}$  and current  $I_{Phase}$ , and compare the result with the total active power  $P_T$  calculated in step 23. Are both values approximately equal?

$$P_T = 3 (E_{Phase} \times I_{Phase}) = \underline{\hspace{2cm}} \text{ W}$$

Yes     No

**Voltage, current, and power measurements in a delta-connected circuit**

In this section, you will set up a delta-connected, three-phase circuit using three load resistors. You will measure the phase voltages and currents in the circuit. You will then modify the circuit in order to measure the line currents in the circuit. You will confirm that the load is balanced and that the ratio between the average line current and the average phase current in the circuit is equal to  $\sqrt{3}$ . You will then calculate the active power dissipated in each phase of the circuit and the total active power dissipated in the circuit using the measured phase voltages and currents. Finally, you will calculate the total active power dissipated in the circuit using the measured average phase voltage and current, and compare the two calculated total active power values.

26. Set up the delta-connected, resistive, three-phase circuit shown in Figure 7.

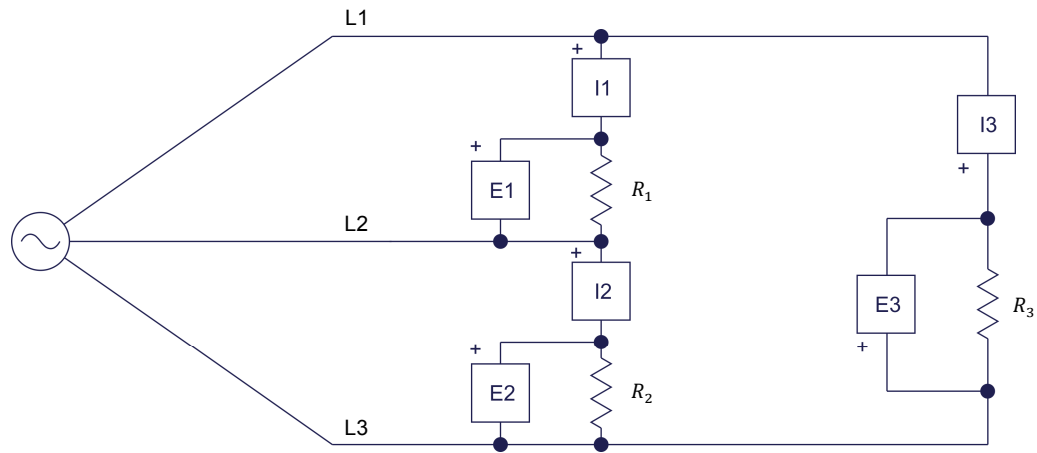

Local ac power network		$R_1$ ( $\Omega$ )	$R_2$ ( $\Omega$ )	$R_3$ ( $\Omega$ )
Voltage (V)	Frequency (Hz)			
120	60	300	300	300
220	50	1100	1100	1100
240	50	1200	1200	1200
220	60	1100	1100	1100

Figure 7. Delta-connected, three-phase circuit supplying power to a three-phase resistive load.

27. Make the necessary switch settings on the **Resistive Load** module in order to obtain the resistance values required.



28. Turn the three-phase ac power source in the **Power Supply** on.

Measure and record below the voltages and currents in the circuit of Figure 7, then turn the three-phase ac power source in the **Power Supply** off.

**CAUTION**

Do not leave the three-phase ac power source on for a long time as the power the resistors dissipate exceeds their nominal power rating.

$$E_{R1} = \underline{\hspace{2cm}} \text{ V}$$

$$E_{R2} = \underline{\hspace{2cm}} \text{ V}$$

$$E_{R3} = \underline{\hspace{2cm}} \text{ V}$$

$$I_{R1} = \underline{\hspace{2cm}} \text{ A}$$

$$I_{R2} = \underline{\hspace{2cm}} \text{ A}$$

$$I_{R3} = \underline{\hspace{2cm}} \text{ A}$$

29. Compare the individual load voltages  $E_{R1}$ ,  $E_{R2}$ , and  $E_{R3}$  measured in the previous step. Are they approximately equal?

Yes     No

Compare the individual load currents  $I_{R1}$ ,  $I_{R2}$ , and  $I_{R3}$  measured in the previous step. Are they approximately equal?

Yes     No

Does this mean that the load is balanced?

Yes     No

30. Calculate the average phase current  $I_{phase}$  using the phase current values recorded in step 28.

$$\text{Average } I_{phase} = \frac{I_{R1} + I_{R2} + I_{R3}}{3} = \underline{\hspace{2cm}} \text{ A}$$

31. Reconnect meter inputs *I1*, *I2*, and *I3* as shown in Figure 8 to measure the line currents in the delta-connected, three-phase circuit.

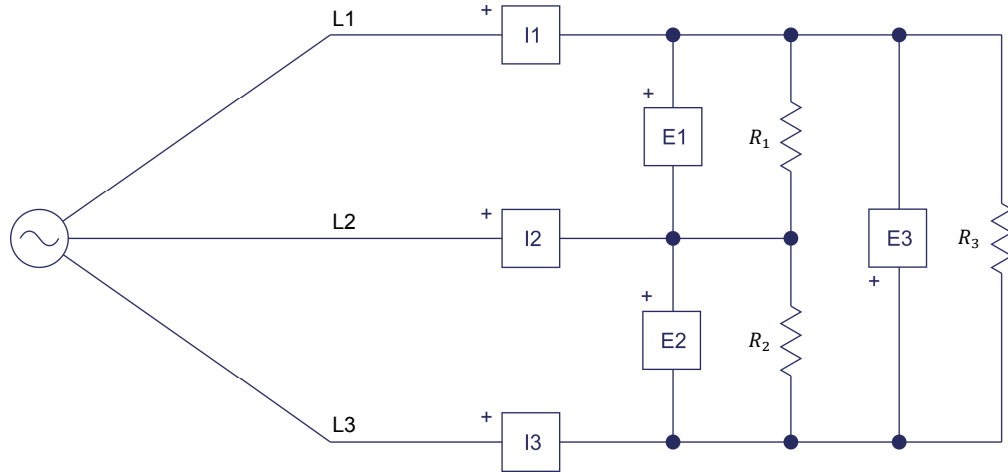

Figure 8. Line current measurements in the delta-connected, three-phase circuit.

32. Turn the three-phase ac power source in the Power Supply on.

Measure and record below the line currents in the circuit of Figure 8, then turn the three-phase ac power source in the Power Supply off. Then, determine the average value of the line currents.

**CAUTION**

Do not leave the three-phase ac power source on for a long time as the power the resistors dissipate exceeds their nominal power rating.

$$I_{Line\ 1} = \text{_____} \text{ A}$$

$$I_{Line\ 2} = \text{_____} \text{ A}$$

$$I_{Line\ 3} = \text{_____} \text{ A}$$

$$\text{Average } I_{Line} = \frac{I_{Line\ 1} + I_{Line\ 2} + I_{Line\ 3}}{3} = \text{_____} \text{ A}$$

33. Calculate the ratio of the average line current  $I_{Line}$  calculated in the previous step to the average phase current  $I_{Phase}$  recorded in step 30.

$$\frac{\text{Average } I_{Line}}{\text{Average } I_{Phase}} = \text{_____}$$

Is the ratio approximately equal to  $\sqrt{3}$ ?

- Yes     No

34. Calculate the active power dissipated in each phase of the circuit and the total active power  $P_T$  dissipated in the circuit using the voltages and currents recorded in step 28.

$$P_{R1} = E_{R1} \times I_{R1} = \underline{\hspace{2cm}} \text{ W}$$

$$P_{R2} = E_{R2} \times I_{R2} = \underline{\hspace{2cm}} \text{ W}$$

$$P_{R3} = E_{R3} \times I_{R3} = \underline{\hspace{2cm}} \text{ W}$$

$$P_T = P_{R1} + P_{R2} + P_{R3} = \underline{\hspace{2cm}} \text{ W}$$

35. Calculate the average phase voltage  $E_{Phase}$  using the phase voltages recorded in step 28.

$$\text{Average } E_{Phase} = \frac{E_{R1} + E_{R2} + E_{R3}}{3} = \underline{\hspace{2cm}} \text{ V}$$

36. Calculate the total active power  $P_T$  dissipated in the circuit using the average phase voltage  $E_{Phase}$  recorded in the previous step and average phase current  $I_{Phase}$  recorded in step 30, and compare the result with the total active power  $P_T$  calculated in step 34. Are both values approximately equal?

$$P_T = 3 (E_{Phase} \times I_{Phase}) = \underline{\hspace{2cm}} \text{ W}$$

Yes       No

37. Close **LVDAC-EMS**, then turn off all the equipment. Disconnect all leads and return them to their storage location.

### CONCLUSION

In this exercise, you learned what three-phase circuits are. You saw the difference between line and phase voltages, and line and phase currents, as well as the relationship between line and phase parameter values in wye- and delta-connected three-phase circuits. You learned what the phase sequence of a three-phase circuit is. You also learned how to calculate the active power dissipated in each phase of a three-phase circuit, and how to calculate the total active power dissipated in a three-phase circuit. Finally, you used voltage and current measurements to confirm the theory and calculations presented in the exercise.

### REVIEW QUESTIONS

1. Explain the difference between the phase voltage and the line voltage in a three-phase circuit.

---



---



---



---

2. What is the ratio between the line and phase voltages and the ratio between the line and phase currents in a wye-connected, three-phase circuit?

---

---

---

3. What is the ratio between the line and phase voltages and the ratio between the line and phase currents in a delta-connected, three-phase circuit?

---

---

---

4. The phase voltage  $E_{phase}$  measured across a balanced, wye-connected, three-phase resistive load is 60 V. Calculate the line voltage  $E_{Line}$ , as well as the current  $I_N$  flowing in the neutral line.

---

---

---

5. In a balanced, delta-connected, resistive, three-phase circuit, the phase voltage  $E_{phase}$  is 120 V and the line current  $I_{Line}$  is 3.46 A. Calculate the total active power  $P_T$  dissipated in the circuit.

---

---

---

## Three-Phase Power Measurement

### EXERCISE OBJECTIVE

When you have completed this exercise, you will be able to calculate active, reactive, and apparent power in balanced, wye- or delta-connected, three-phase circuits. You will know how to use a power meter to measure power in single-phase circuits. You will also know how to measure power in three- and four-wire, three-phase circuits.

### DISCUSSION OUTLINE

The Discussion of this exercise covers the following points:

- Calculating power in balanced three-phase circuits
- Power measurements in single-phase circuits
- Measuring the total power in four-wire, three-phase circuits
- Measuring the total power in three-wire, three-phase circuits (two-wattmeter method)
- Measuring the total power in four-wire, three-phase circuits using the two-wattmeter method

### DISCUSSION

#### Calculating power in balanced three-phase circuits

As seen in the previous exercise, the total active power  $P_T$  supplied to a balanced three-phase load (i.e., the total active power dissipated in a circuit) can be calculated using the following equation:

$$P_T = 3 \times P_{Phase} = 3 (E_{Phase} \times I_{Phase} \times \cos \varphi)$$

In a wye-connected circuit,  $E_{Phase} = E_{Line}/\sqrt{3}$  and the phase current  $I_{Phase}$  is equal to the line current  $I_{Line}$ . The above equation then becomes:

$$P_T = \frac{3}{\sqrt{3}} \times E_{Line} \times I_{Line} \times \cos \varphi$$

The  $3/\sqrt{3}$  factor can be simplified to  $\sqrt{3}$ , so that the final equation for the total active power dissipated in the wye-connected circuit is:

$$P_T = \sqrt{3} (E_{Line} \times I_{Line} \times \cos \varphi) \quad (3)$$

where  $P_T$  is the total active power dissipated in the three-phase circuit, expressed in watts (W)

In a delta-connected circuit, the same equation is obtained because the phase voltage  $E_{Phase}$  is equal to the line voltage  $E_{Line}$ , and  $I_{Phase} = I_{Line}/\sqrt{3}$ . Therefore, in either a balanced wye-connected circuit or a balanced delta-connected circuit, the total active power  $P_T$  dissipated in the three-phase circuit can be calculated using Equation (3).

Since  $(E_{Phase} \times I_{Phase} \times \cos \varphi)$  is the expression representing the active power  $P_{Phase}$  dissipated in a single phase of a three-phase circuit, it follows that the expression  $E_{Phase} \times I_{Phase}$  represents the apparent power in a single phase. The total apparent power  $S_T$  in a balanced, wye- or delta-connected, three-phase circuit can thus be calculated using the following equation:

$$S_T = 3 (E_{Phase} \times I_{Phase}) \quad (4)$$

where  $S_T$  is the total apparent power in the three-phase circuit, expressed in volt-amperes (VA)

Following the same steps used to obtain the equation for calculating the total active power  $P_T$  in three-phase circuits using the line voltage  $E_{Line}$  and the line current  $I_{Line}$ , the equation for the total apparent power  $S_T$  in a three-phase circuit can be rewritten as follows:

$$S_T = \sqrt{3} (E_{Line} \times I_{Line})$$

The power factor of a balanced three-phase circuit is the ratio of the total active power to the total apparent power (i.e.,  $P_T/S_T$ ), and the relationship between  $P_T$ ,  $Q_T$ , and  $S_T$  is the same as for single-phase ac circuits (i.e.,  $S_T^2 = P_T^2 + Q_T^2$ ). Thus, the total reactive power  $Q_T$  in a three-phase circuit can be calculated using the following equation:

$$Q_T = \sqrt{S_T^2 - P_T^2} \quad (5)$$

where  $Q_T$  is the total reactive power in the three-phase circuit, expressed in reactive volt-amperes (var)

### Power measurements in single-phase circuits

Commercial instruments are available to measure active, reactive, and apparent power directly. These instruments are referred to as power meters. A selector on the power meter usually allows the unit to measure active, reactive, or apparent power. A power meter determines power by measuring the circuit voltage and current. All power meters thus generally have at least a voltage input and a current input to measure the circuit voltage and current. Figure 9a shows the typical connections of a power meter in a single-phase circuit and Figure 9b shows the equivalent connections required to measure power using the Data Acquisition and Control Interface (DACI) module.

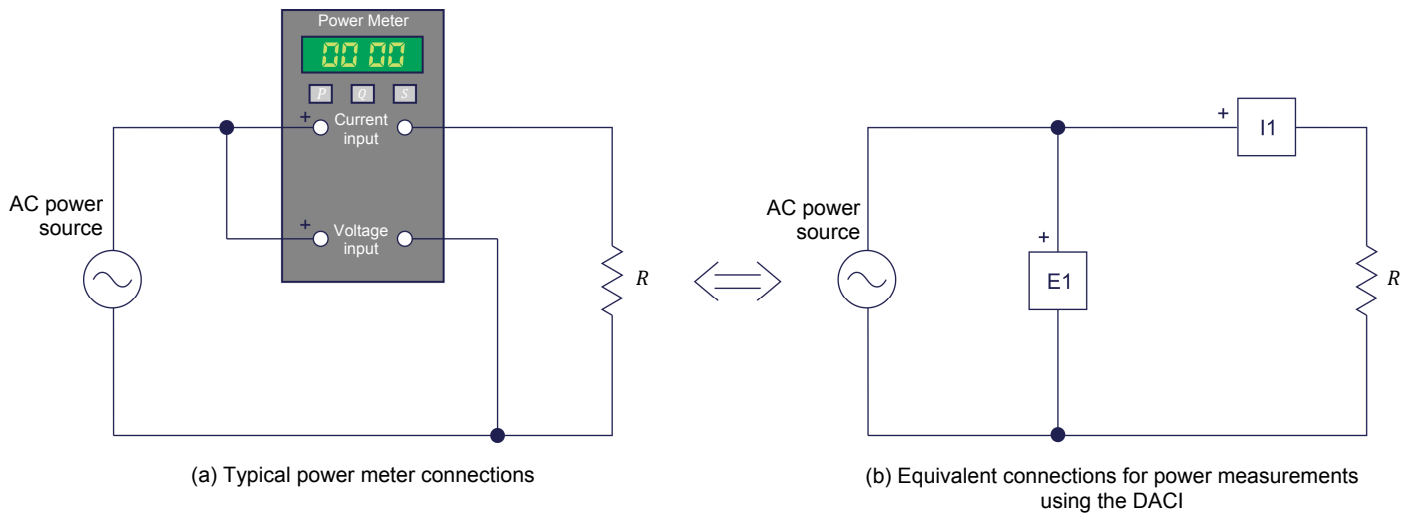

Figure 9. Three-phase circuit diagrams showing the connections required for power measurements.

### Measuring the total power in four-wire, three-phase circuits

Measuring the total power in a four-wire, three-phase circuit is done by first measuring the voltage and current in each phase of the circuit (i.e., the voltage across each load element and the current flowing in each load element) and calculating the active power and reactive power in each phase from the voltage and current measured in each phase of the circuit. The total active power  $P_T$  in the four-wire, three-phase circuit is simply the algebraic sum of the active power values obtained for the three phases of the circuit. Similarly, the total reactive power  $Q_T$  is simply the algebraic sum of the reactive power values obtained for the three phases of the circuit.

In other words, it is like measuring the active power and reactive power in each phase independently using three power meters and algebraically adding the three measured power (either active or reactive) values. The total apparent power  $S_T$  can then be obtained by computing the vectorial sum of the total active power  $P_T$  and the total reactive power  $Q_T$ . Figure 10 shows the connections required to measure the total power in a four-wire, three-phase circuit using the DACI. Note that, in the circuit diagram, inputs E1 and I1, inputs E2 and I2, and inputs E3 and I3 each represent a power meter.



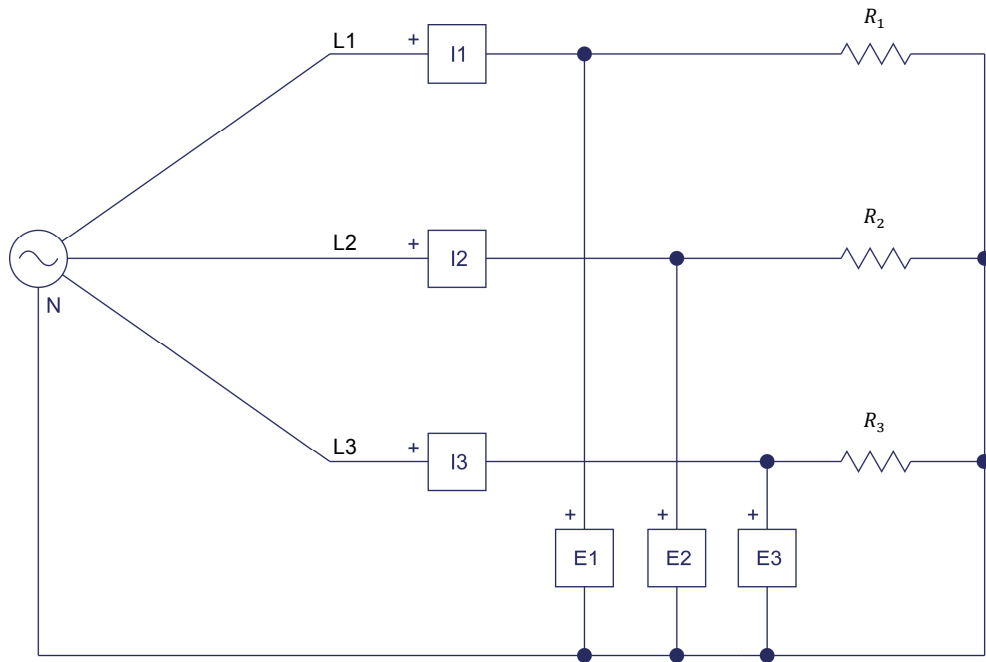

Figure 10. Three-phase power measurement using three power meters.

The method of power measurement shown in Figure 10 works whether the three-phase circuit is balanced or not.

### Measuring the total power in three-wire, three-phase circuits (two-wattmeter method)

A three-wire, three-phase circuit is simply a three-phase circuit with three line conductors but no neutral conductor. Three-wire, three-phase circuits are used commonly because they allow three-phase power to be conveyed using three conductors instead of four conductors. This makes three-wire, three-phase circuits more economical than four-wire, three-phase circuits.

The method for measuring the total power in four-wire, three-phase circuits discussed in the previous section cannot be used to measure the total power in three-wire, three-phase circuits. For instance, when the load is connected in a wye configuration, the phase currents can be measured but the phase voltages (voltage across each load element) cannot because the neutral point generally is not available to connect the voltage inputs of the power meters, as Figure 11 shows.

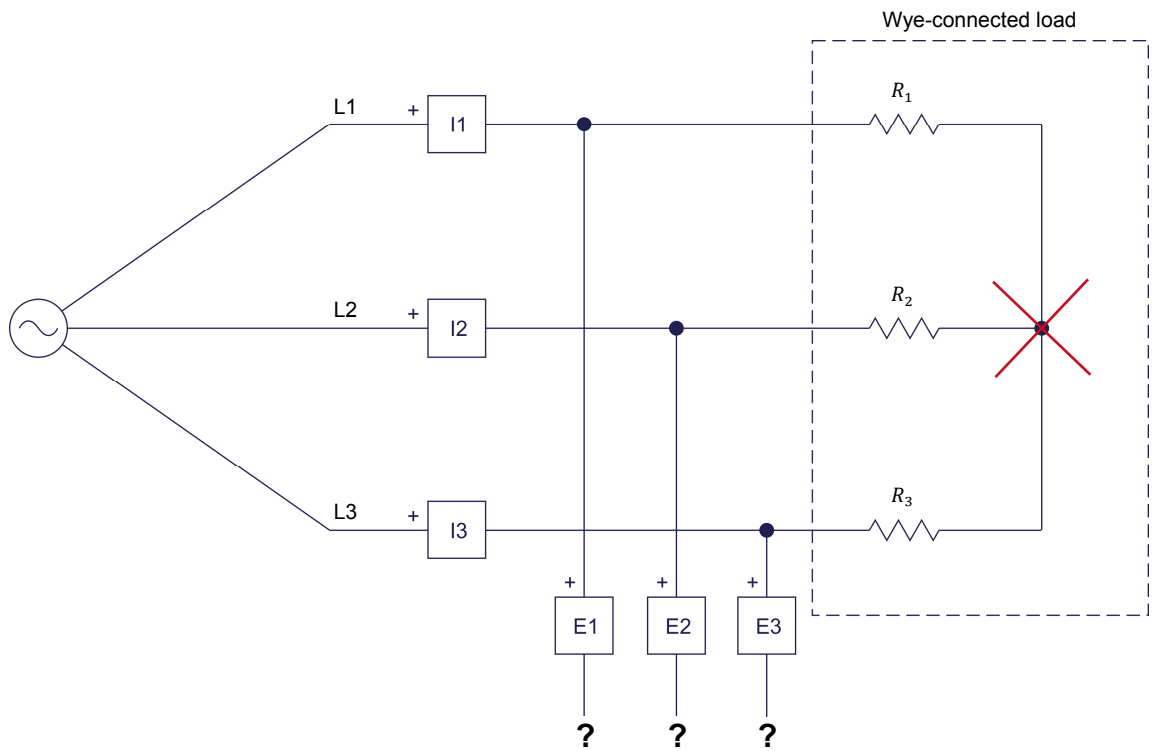

**Figure 11.** Diagram of a three-wire, wye-connected, three-phase circuit showing that the voltage inputs of the power meters generally cannot be connected to the neutral point of the circuit.

Similarly, when the load is connected in a delta configuration, the phase voltages can be measured but the phase currents (current flowing through each load element) cannot be measured because individual access to each load element generally is not possible (i.e., it is impossible to connect the current inputs of the power meters to measure the phase currents), as Figure 12 shows.

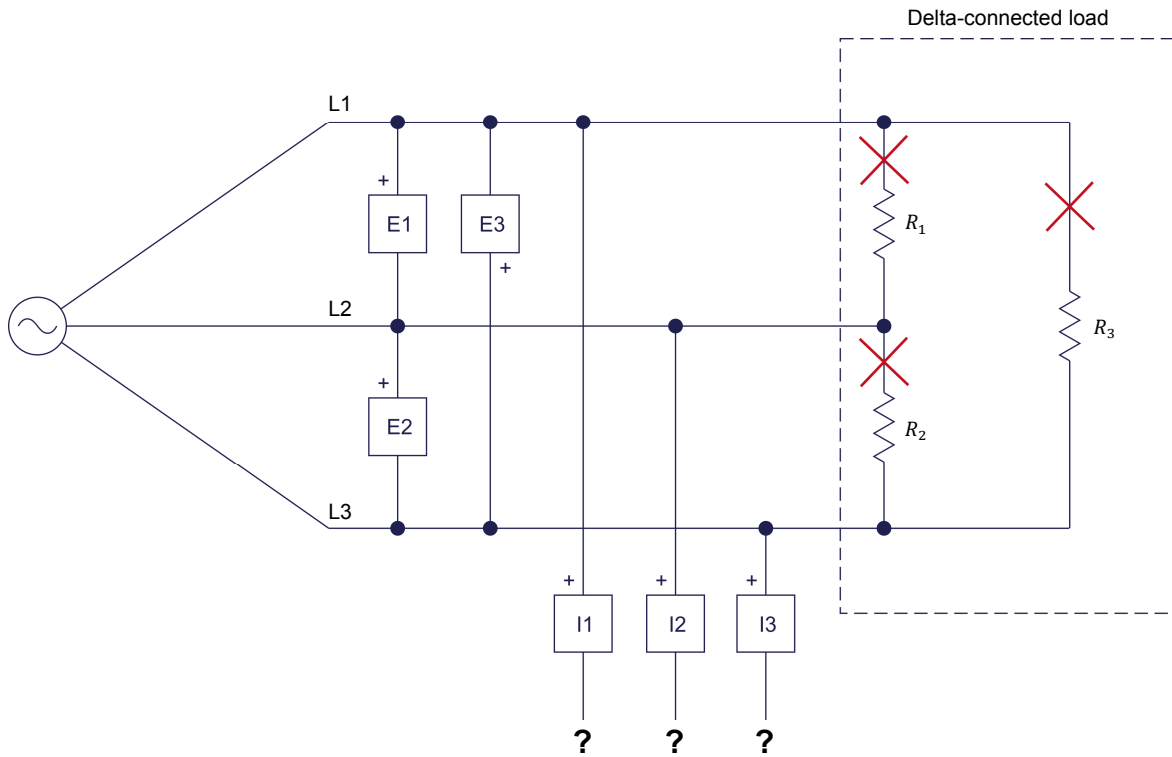

**Figure 12. Diagram of a three-wire, delta-connected, three-phase circuit showing that the current inputs of the power meters cannot be connected to measure the phase currents.**

To measure the total power (either the total active power  $P_T$ , the total reactive power  $Q_T$ , or the total apparent power  $S_T$ ) in three-wire, three-phase circuits, a method using only two power meters can be used. This method is usually referred to as the **two-wattmeter method** because historically, it was first implemented with two wattmeters instead of two power meters. Figure 13 shows the connections of the voltage and current inputs of the two power meters required for the two-wattmeter method of measuring three-phase power. Note that the voltage and current inputs of the power meters must be connected with the polarity indicated in the figure in order to obtain correct power measurements.

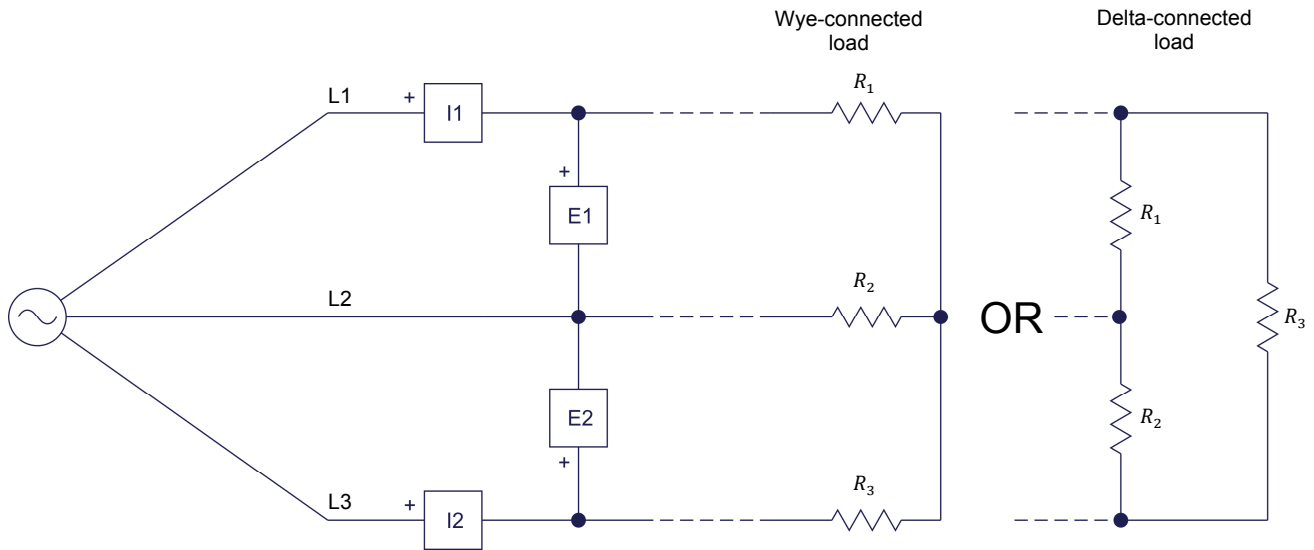

**Figure 13. Connections of the voltage and current inputs of the power meters to a three-wire, three-phase circuit when measuring the total power using the two-wattmeter method.**

The total active power  $P_T$  in the three-wire, three-phase circuit is simply the algebraic sum of the active power values indicated by the two power meters. Similarly, the total reactive power  $Q_T$  is simply the algebraic sum of the reactive power values indicated by the two power meters. The total apparent power  $S_T$  can then be obtained by computing the vectorial sum of the total active power  $P_T$  and the total reactive power  $Q_T$ . This method of power measurement works whether the three-phase circuit is balanced or not.

### **Measuring the total power in four-wire, three-phase circuits using the two-wattmeter method**

The two-wattmeter method of power measurement can also be used to measure the total power (either active, reactive, or apparent) in four-wire, three-phase circuits. This can be useful because the two-wattmeter method requires only two power meters (i.e., two voltage inputs and two current inputs) instead of three power meters (i.e., three voltage inputs and three current inputs) as with the method seen earlier in this discussion. However, care must be exercised when using the two-wattmeter method to measure the total power in four-wire, three-phase circuits because the method works only with balanced circuits.

## PROCEDURE OUTLINE

The Procedure is divided into the following sections:

- Setup and connections
- Measuring the total power in four-wire, three-phase circuits
- Measuring the total power in three-wire, three-phase circuits (wye configuration)
- Measuring the total power in three-wire, three-phase circuits (delta configuration)
- Measuring the total power in four-wire, three-phase circuits using the two-wattmeter method

## PROCEDURE



High voltages are present in this laboratory exercise. Do not make or modify any banana jack connections with the power on unless otherwise specified.

### Setup and connections

*In this section, you will set up the equipment to measure power in a four-wire, three-phase circuit.*

1. Refer to the Equipment Utilization Chart in Appendix A to obtain the list of equipment required to perform this exercise.

Install the required equipment in the [Workstation](#).

Make sure that the ac and dc power switches on the [Power Supply](#) are set to the O (off) position, then connect the [Power Supply](#) to a three-phase ac power outlet.

Connect the [Power Input](#) of the [Data Acquisition and Control Interface](#) to a 24 V ac power supply. Turn the 24 V ac power supply on.

2. Connect the USB port of the [Data Acquisition and Control Interface](#) to a USB port of the host computer.
3. Turn the host computer on, then start the [LVDAC-EMS](#) software.

In the [LVDAC-EMS Start-Up](#) window, make sure that the [Data Acquisition and Control Interface](#) is detected. Make sure that the [Computer-Based Instrumentation](#) function for the [Data Acquisition and Control Interface](#) is available. Select the network voltage and frequency that correspond to the voltage and frequency of your local ac power network, then click the [OK](#) button to close the [LVDAC-EMS Start-Up](#) window.

4. Set up the circuit shown in Figure 14.

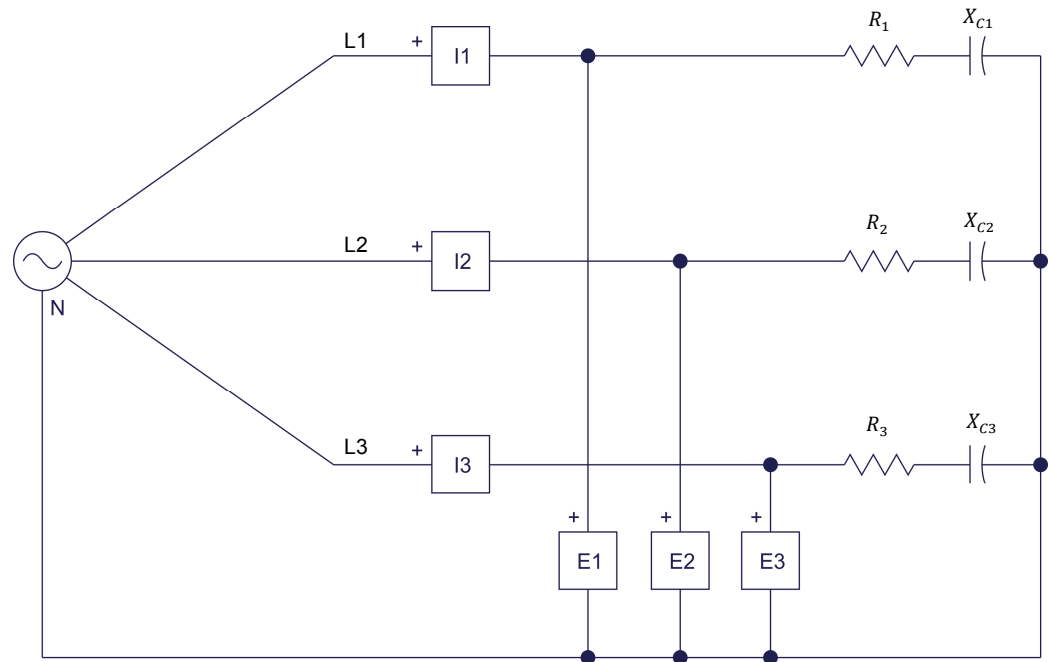

Local ac power network		$R_1, R_2, R_3$ ( $\Omega$ )	$X_{C1}, X_{C2}, X_{C3}$ ( $\Omega$ )
Voltage (V)	Frequency (Hz)		
120	60	171	240
220	50	629	880
240	50	686	960
220	60	629	880

Figure 14. Balanced, four-wire, wye-connected, three-phase circuit set up for power measurements.

5. Make the necessary switch settings on the [Resistive Load](#) and [Capacitive Load](#) modules in order to obtain the resistance and capacitive reactance values required.
6. In [LVDAC-EMS](#), start the [Metering](#) application, then make the required settings in order to measure the rms values (ac) of the phase voltages  $E_{1-N}$ ,  $E_{2-N}$ , and  $E_{3-N}$  (inputs [E1](#), [E2](#), and [E3](#), respectively), and the phase currents  $I_{Phase 1}$ ,  $I_{Phase 2}$ , and  $I_{Phase 3}$  (inputs [I1](#), [I2](#), and [I3](#), respectively). Set three other meters to measure power from inputs [E1](#) and [I1](#) (meter [PQS1](#)), [E2](#) and [I2](#) (meter [PQS2](#)), and [E3](#) and [I3](#) (meter [PQS3](#)). These three power meters will be used to successively measure the active powers  $P_1$ ,  $P_2$ , and  $P_3$ , the reactive powers  $Q_1$ ,  $Q_2$ , and  $Q_3$ , and the apparent powers  $S_1$ ,  $S_2$ , and  $S_3$  in each phase of the circuit. Set the meters to continuous refresh mode.



Voltage and current measurements:

$$E_{1-N} = \underline{\hspace{2cm}} \text{ V} \qquad I_{\text{Phase 1}} = \underline{\hspace{2cm}} \text{ A}$$

$$E_{2-N} = \underline{\hspace{2cm}} \text{ V} \qquad I_{\text{Phase 2}} = \underline{\hspace{2cm}} \text{ A}$$

$$E_{3-N} = \underline{\hspace{2cm}} \text{ V} \qquad I_{\text{Phase 3}} = \underline{\hspace{2cm}} \text{ A}$$

Active, reactive, and apparent power measurements:

$$P_1 = \underline{\hspace{2cm}} \text{ W} \qquad P_2 = \underline{\hspace{2cm}} \text{ W}$$

$$P_3 = \underline{\hspace{2cm}} \text{ W}$$

$$Q_1 = \underline{\hspace{2cm}} \text{ var} \qquad Q_2 = \underline{\hspace{2cm}} \text{ var}$$

$$Q_3 = \underline{\hspace{2cm}} \text{ var}$$

$$S_1 = \underline{\hspace{2cm}} \text{ VA} \qquad S_2 = \underline{\hspace{2cm}} \text{ VA}$$

$$S_3 = \underline{\hspace{2cm}} \text{ VA}$$

9. Compare the voltage, current, and power (active, reactive, and apparent) values measured in the previous step with the parameter values calculated in step 7. Are all values approximately equal?

Yes     No

10. In the **Metering** window, set an additional meter to measure the total power (either active, reactive, or apparent) from the values provided by the meters measuring the power in each phase of the circuit.



*The PQS1 + PQS2 + PQS3 function (accessible through the **Meter Settings** window of the **Metering** application) allows the sum (either algebraic or vectorial) of the power values measured by meters PQS1, PQS2, and PQS3. The total power meter can be set to indicate either the active, reactive, or apparent power value.*

11. Turn the three-phase ac power source in the **Power Supply** on.

Measure and record successively the total active power  $P_T$ , total reactive power  $Q_T$ , and total apparent power  $S_T$  in the circuit using the total power meter set in the previous step, then turn the three-phase ac power source in the **Power Supply** off.

$$P_T = \underline{\hspace{2cm}} \text{ W} \qquad Q_T = \underline{\hspace{2cm}} \text{ var}$$

$$S_T = \underline{\hspace{2cm}} \text{ VA}$$





14. Turn the three-phase ac power source in the **Power Supply** on.

Successively measure and record the active power  $P_T$ , reactive power  $Q_T$ , and apparent power  $S_T$  in the circuit using the total power meter you set up before, then turn the three-phase ac power source in the **Power Supply** off.

$$P_T = \text{_____ W}$$

$$Q_T = \text{_____ var}$$

$$S_T = \text{_____ VA}$$

15. Compare the total active power  $P_T$ , total reactive power  $Q_T$ , and total apparent power  $S_T$  measured in the previous step with the total power values calculated in step 13. Are all values approximately equal?

Yes     No

Do the circuit measurements performed in this section confirm that the total power in both balanced and unbalanced, four-wire, three-phase circuits can be measured using three power meters?

Yes     No

### Measuring the total power in three-wire, three-phase circuits (wye configuration)

*In this section, you will set up a balanced, three-wire, wye-connected, three-phase circuit. You will measure the total active, reactive, and apparent power values in the circuit using the two-wattmeter method, and verify that the measured power values are equal to the calculated power values, thus confirming that the two-wattmeter method of power measurement works for measuring the total power in balanced, three-wire, three-phase circuits.*

16. Set up the circuit shown in Figure 15.



*The balanced, three-phase load in the circuit of Figure 15 is identical to the balanced, three-phase load used in the previous section of this exercise. The total active power  $P_T$ , total reactive power  $Q_T$ , and total apparent power  $S_T$  are thus equal to those calculated in the previous section (see step 7) of the exercise.*

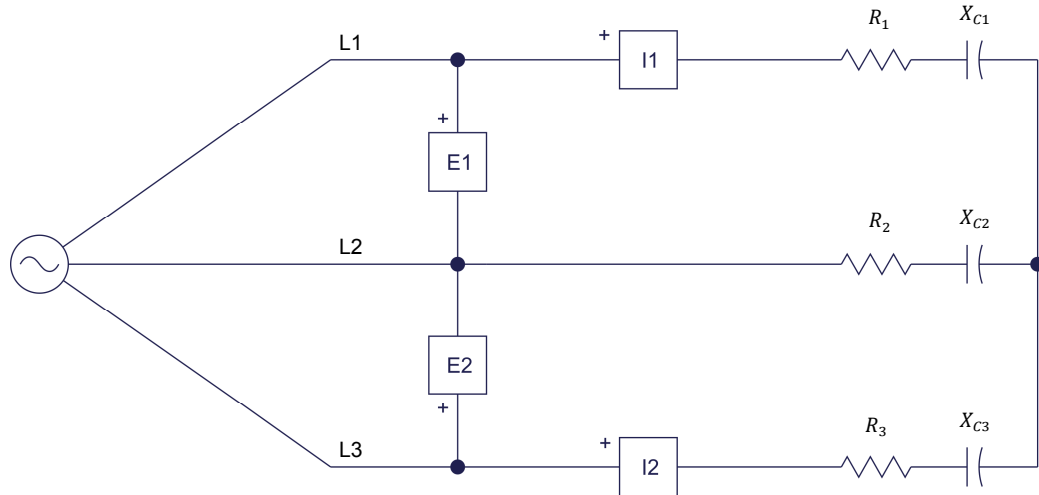

Local ac power network		$R_1, R_2, R_3$ ( $\Omega$ )	$X_{C1}, X_{C2}, X_{C3}$ ( $\Omega$ )
Voltage (V)	Frequency (Hz)		
120	60	171	240
220	50	629	880
240	50	686	960
220	60	629	880

Figure 15. Balanced, three-wire, wye-connected, three-phase circuit set up for power measurements using the two-wattmeter method.

17. Make the necessary switch settings on the **Resistive Load** and **Capacitive Load** modules in order to obtain the resistance and capacitive reactance values required.
18. In the **Metering** window, make the required settings in order to measure the rms values (ac) of the line voltages  $E_{1-2}$  and  $E_{3-2}$  (inputs **E1** and **E2**, respectively), and the line currents  $I_{Line 1}$  and  $I_{Line 3}$  (inputs **I1** and **I2**). Set two meters to measure power from inputs **E1** and **I1** (meter **PQS1**) and inputs **E2** and **I2** (meter **PQS2**). Set another meter to measure the total power from the power values provided by meters **PQS1** and **PQS2**.



The **PQS1 + PQS2** function (accessible through the **Meter Settings** window of the **Metering** application) allows the sum (either algebraic or vectorial) of the power values measured by meters **PQS1** and **PQS2**. The total power meter can be set to indicate either the active, reactive, or apparent power value.

19. Turn the three-phase ac power source in the **Power Supply** on.

Successively measure and record the total active power  $P_T$ , total reactive power  $Q_T$ , and total apparent power  $S_T$  in the circuit using the meter you set up for total power measurement, then turn the three-phase ac power source in the **Power Supply** off.

$$P_T = \underline{\hspace{2cm}} \text{ W} \qquad Q_T = \underline{\hspace{2cm}} \text{ var}$$

$$S_T = \underline{\hspace{2cm}} \text{ VA}$$

20. Compare the total active power  $P_T$ , total reactive power  $Q_T$ , and total apparent power  $S_T$  measured in the previous step with the total power values calculated in step 7. Are all values approximately equal?

Yes     No

Do the circuit measurements performed in this section confirm that the two-wattmeter method of power measurement can be used to measure the total power in balanced, three-wire, wye-connected, three-phase circuits?

Yes     No

### Measuring the total power in three-wire, three-phase circuits (delta configuration)

*In this section, you will set up a balanced, three-wire, delta-connected, three-phase circuit. You will solve the circuit by calculating the active, reactive, and apparent power values in each phase of the circuit, and the total active, reactive, and apparent power values in the circuit. You will measure the total active, reactive, and apparent power values in the circuit using the two-wattmeter method, and confirm that the measured values are equal to the calculated values. You will then unbalance the three-phase circuit by modifying the impedance in one phase of the circuit, and solve the resulting unbalanced three-phase circuit. Finally, you will measure the total active, reactive, and apparent power values in the circuit using the two-wattmeter method, and verify that the measured values are equal to the calculated values, thus confirming that the two-wattmeter method of power measurement can be used to measure the total power in both balanced and unbalanced, three-wire, three-phase circuits.*



24. Turn the three-phase ac power source in the **Power Supply** on.

Successively measure and record the total active power  $P_T$ , total reactive power  $Q_T$ , and total apparent power  $S_T$  in the circuit using the meter you set up for total power measurement, then turn the three-phase ac power source in the **Power Supply** off.

$$P_T = \text{_____ W} \qquad Q_T = \text{_____ var}$$

$$S_T = \text{_____ VA}$$

25. Compare the total active power  $P_T$ , total reactive power  $Q_T$ , and total apparent power  $S_T$  measured in the previous step with the total power values calculated in step 23. Are all values approximately equal?

Yes     No

26. Modify the switch settings on the **Resistive Load** and **Capacitive Load** modules in the circuit of Figure 16 in order to obtain the resistance and capacitive reactance values indicated in Table 2. Due to these modifications, the three-phase load is now unbalanced (i.e., the first phase of the circuit has a different impedance from that of the second and third phases).

**Table 2. Resistance and capacitive reactance values used for unbalancing the three-wire, delta-connected, three-phase circuit in Figure 16.**

Local ac power network		$R_1$ ( $\Omega$ )	$R_2, R_3$ ( $\Omega$ )	$X_{C1}$ ( $\Omega$ )	$X_{C2}, X_{C3}$ ( $\Omega$ )
Voltage (V)	Frequency (Hz)				
120	60	300	171	600	240
220	50	1100	629	2200	880
240	50	1200	686	2400	960
220	60	1100	629	2200	880

27. Solve the circuit in Figure 16 using the resistance and capacitive reactance values indicated in Table 2, to determine the following parameters: the total active power  $P_T$ , total reactive power  $Q_T$ , and total apparent power  $S_T$  in the circuit.

---

---

---

---

---

---

---

---

---

---

28. Turn the three-phase ac power source in the **Power Supply** on.

Successively measure and record the total active power  $P_T$ , total reactive power  $Q_T$ , and total apparent power  $S_T$  in the circuit using the meter you set up for total power measurement, then turn the three-phase ac power source in the **Power Supply** off.

$$P_T = \underline{\hspace{2cm}} \text{ W} \qquad Q_T = \underline{\hspace{2cm}} \text{ var}$$

$$S_T = \underline{\hspace{2cm}} \text{ VA}$$

29. Compare the total active power  $P_T$ , total reactive power  $Q_T$ , and total apparent power  $S_T$  measured in the previous step with the total power values calculated in step 27. Are all values approximately equal?

Yes       No

Do the circuit measurements performed in this section confirm that the two-wattmeter method of power measurement can be used to measure the total power in both balanced and unbalanced, three-wire, delta-connected, three-phase circuits?

Yes       No

### Measuring the total power in four-wire, three-phase circuits using the two-wattmeter method

*In this section, you will set up a balanced, four-wire, wye-connected, three-phase circuit similar (same load but voltage and current inputs connected for total power measurement using the two-wattmeter method) to the one you set up in the “Measuring the total power in four-wire, three-phase circuits” section of this exercise. You will measure the total active, reactive, and apparent power values in the circuit using the two-wattmeter method, and confirm that the measured values are equal to the values calculated for this balanced, three-phase circuit in the “Measuring the total power in four-wire, three-phase circuits” section of this exercise. You will then unbalance the three-phase circuit by modifying the impedance in one phase of the circuit. Finally, you will measure the total active, reactive, and apparent power values in the circuit, and verify that the measured values differ from the values calculated for this unbalanced, three-phase circuit in the “Measuring the total power in four-wire, three-phase circuits” section of this exercise. You will confirm that the two-wattmeter method of power measurement can only be used to measure power in four-wire, three-phase circuits that are balanced.*

30. Set up the circuit shown in Figure 17.

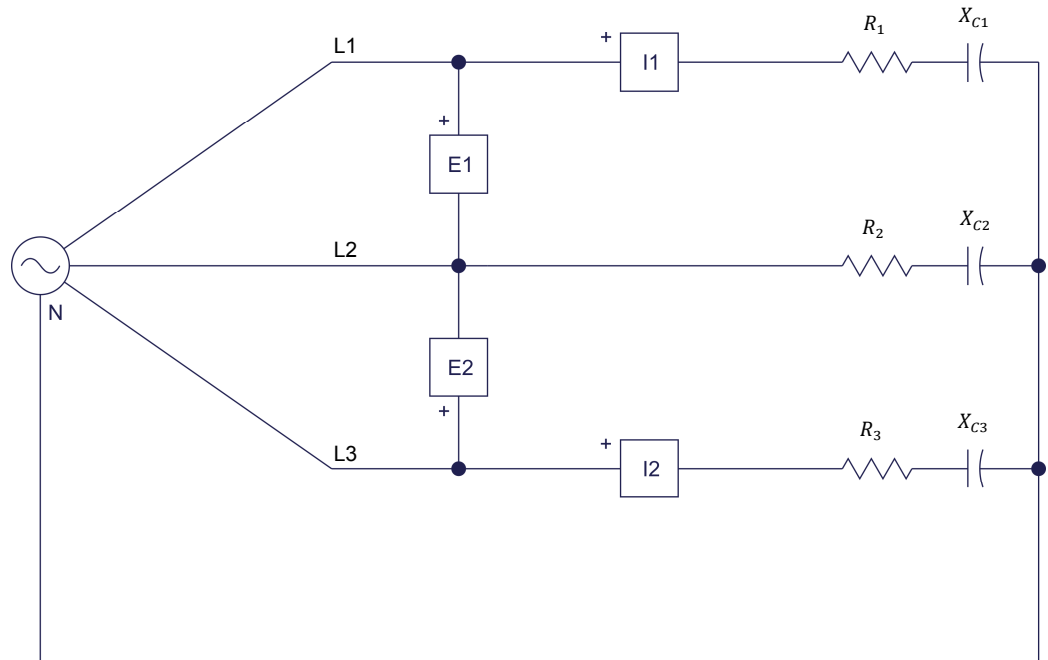

Local ac power network		$R_1, R_2, R_3$ ( $\Omega$ )	$X_{C1}, X_{C2}, X_{C3}$ ( $\Omega$ )
Voltage (V)	Frequency (Hz)		
120	60	171	240
220	50	629	880
240	50	686	960
220	60	629	880

Figure 17. Four-wire, wye-connected, three-phase circuit set up for power measurements using the two-wattmeter method.

31. Make the necessary switch settings on the [Resistive Load](#) and [Capacitive Load](#) modules in order to obtain the resistance and capacitive reactance values required.



*The balanced, three-phase circuit you just set up corresponds to the balanced, four-wire three-phase circuit set up in the “Measuring the total power in four-wire, three-phase circuits” section of this exercise. The calculations required for solving the circuit are identical and do not need to be repeated.*

32. Turn the three-phase ac power source in the [Power Supply](#) on.



Successively measure and record the total active power  $P_T$ , total reactive power  $Q_T$ , and total apparent power  $S_T$  in the circuit using the meter you set up for total power measurement, then turn the three-phase ac power source in the **Power Supply** off.

$$P_T = \text{_____ W} \qquad Q_T = \text{_____ var}$$

$$S_T = \text{_____ VA}$$

- 33.** Compare the total active power  $P_T$ , total reactive power  $Q_T$ , and total apparent power  $S_T$  measured in the previous step with the total power values calculated in step 7. Are all values approximately equal?

Yes     No

- 34.** Modify the switch settings on the **Resistive Load** and **Capacitive Load** modules in the circuit of Figure 17 in order to obtain the resistance and capacitive reactance values indicated in Table 3. Due to these modifications, the three-phase load is now unbalanced (i.e., the first phase of the circuit has a different impedance from that of the second and third phases).

**Table 3.** Resistance and capacitive reactance values used for unbalancing the four-wire, wye-connected, three-phase circuit.

Local ac power network		$R_1$ ( $\Omega$ )	$R_2, R_3$ ( $\Omega$ )	$X_{C1}$ ( $\Omega$ )	$X_{C2}, X_{C3}$ ( $\Omega$ )
Voltage (V)	Frequency (Hz)				
120	60	300	171	600	240
220	50	1100	629	2200	880
240	50	1200	686	2400	960
220	60	1100	629	2200	880



*The unbalanced, three-phase circuit you just set up corresponds to the unbalanced, four-wire, three-phase circuit set up in the “Measuring the total power in four-wire, three-phase circuits” section of this exercise. The calculations required for solving the circuit are identical and do not need to be repeated.*

- 35.** Turn the three-phase ac power source in the **Power Supply** on.

Successively measure and record the total active power  $P_T$ , total reactive power  $Q_T$ , and total apparent power  $S_T$  in the circuit using the meter you set up for total power measurement, then turn the three-phase ac power source in the **Power Supply** off.

$$P_T = \text{_____ W} \qquad Q_T = \text{_____ var}$$

$$S_T = \text{_____ VA}$$

36. Compare the total active power  $P_T$ , total reactive power  $Q_T$ , and total apparent power  $S_T$  values measured in the previous step with the total power values calculated in step 13. Are all values equal?

Yes     No

What conclusions can you draw concerning the two-wattmeter method of power measurement when measuring power in four-wire, three-phase circuits?

---

---

---

---

37. Close **LVDAC-EMS**, then turn off all the equipment. Disconnect all leads and return them to their storage location.

**CONCLUSION**

In this exercise, you learned how to calculate active, reactive, and apparent power in balanced, wye- and delta-connected, three-phase circuits. You also learned how to use power meters to measure power in three-phase circuits. You saw how to measure power in three- and four-wire, three-phase circuits, as well as when it is possible to use the two-wattmeter method of power measurement to measure power in a three-phase circuit.

**REVIEW QUESTIONS**

1. A balanced, delta-connected, purely resistive, three-phase circuit has a line voltage  $E_{Line}$  of 100 V and a line current  $I_{Line}$  of 1.5 A. Calculate the total active power  $P_T$  dissipated in the resistive load of the circuit.

---

---

---

2. Explain how to connect the two power meters to the lines of a three-wire, three-phase circuit when using the two-wattmeter method of power measurement.

---

---

---

---

---

3. A balanced, wye-connected, resistive and capacitive, three-phase circuit has a phase voltage  $E_{phase}$  of 80 V and a phase current  $I_{phase}$  of 2.5 A. Calculate the total apparent power  $S_T$  in the circuit.

---

---

4. A balanced, three-wire, resistive and capacitive, three-phase circuit is connected to two power meters set up to measure power using the two-wattmeter method of power measurement. The two power meters indicate active power readings of 175 W and -35 W. Calculate the total active power  $P_T$  dissipated in the circuit.

---

---

5. In which type of three-phase circuits does the two-wattmeter method of power measurement not work to measure the total power in the circuit?

---

---

## Phase Sequence

### EXERCISE OBJECTIVE

When you have completed this exercise, you will know what a phase sequence is and why it is important to know the phase sequence of a three-phase power system. You will be able to determine the phase sequence of a three-phase power system using an oscilloscope.

### DISCUSSION OUTLINE

The Discussion of this exercise covers the following points:

- Phase sequence fundamentals
- Determining the phase sequence of a three-phase power system using an oscilloscope
- Connecting an oscilloscope to a three-phase power system

### DISCUSSION

#### Phase sequence fundamentals

As mentioned earlier in this manual, a three-phase power system is a polyphase system in which three voltages  $E_A$ ,  $E_B$ , and  $E_C$  have an equal magnitude and are displaced  $120^\circ$  from each other. However, simply stating that the voltages are  $120^\circ$  out of phase with each other is not sufficient to fully describe the system. The order in which the voltages succeed each other, i.e., the phase sequence of the power system, is also important.

The phase sequence of a power system is determined directly at the power generating station by the direction of rotation of the ac generators. Figure 18a shows a three-phase power system rotating in clockwise (cw) direction. The phase sequence is thus A-B-C-A-B-C.... Figure 18b and Figure 18c show the resulting phase voltage waveforms and phase voltage phasor diagram, respectively.

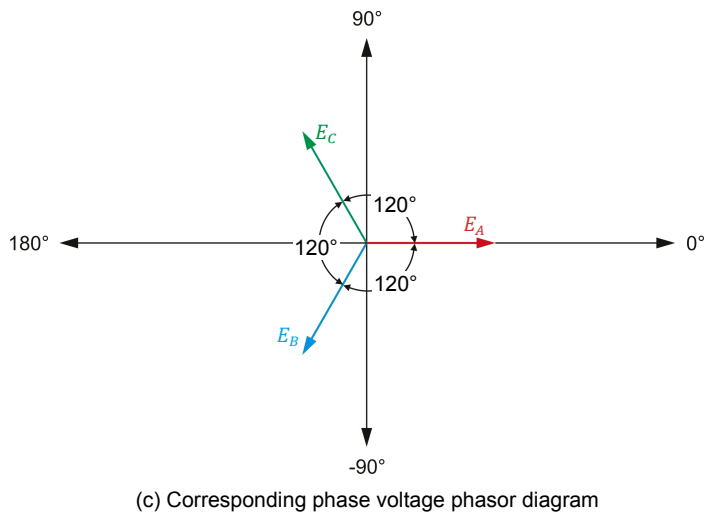
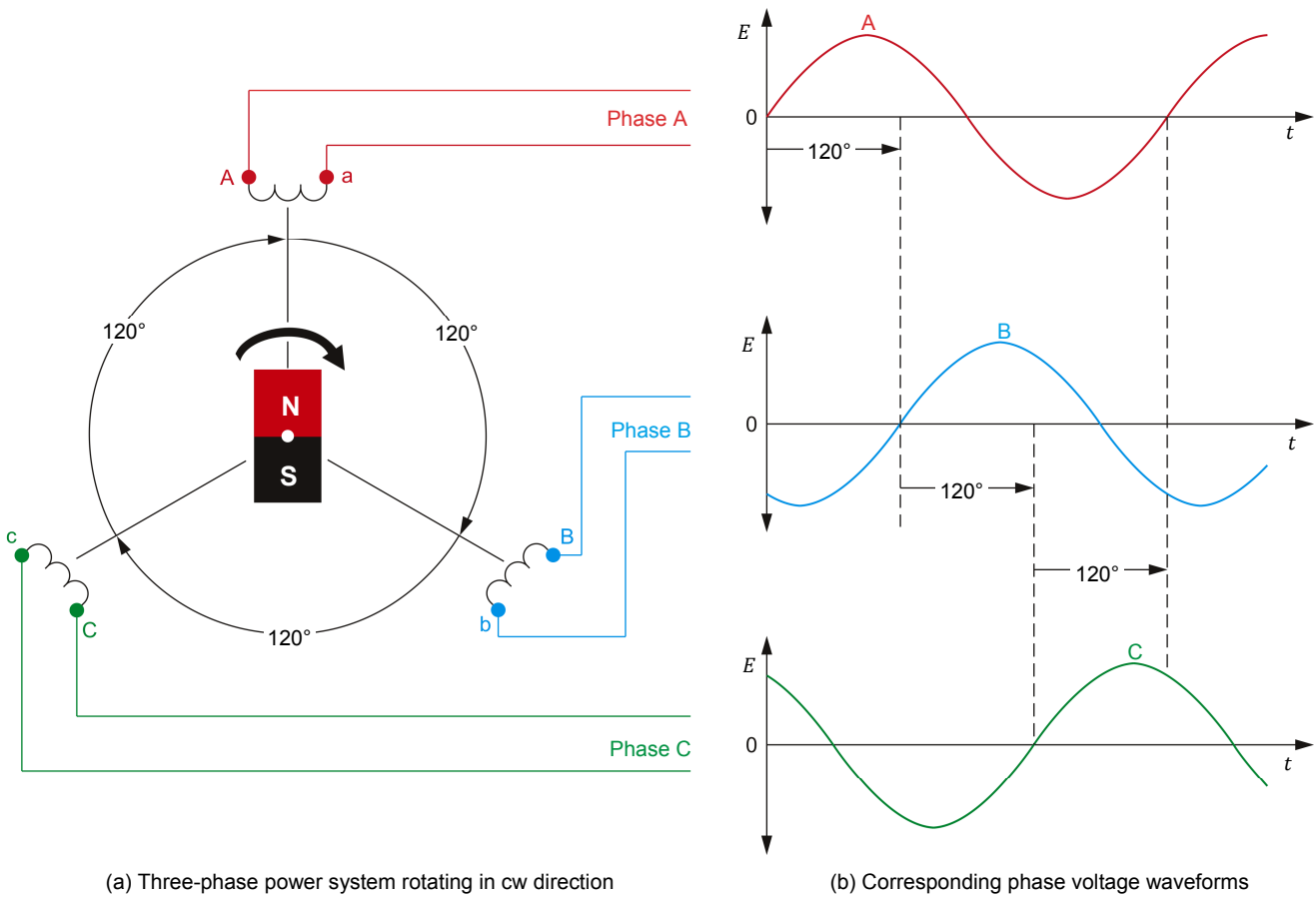

Figure 18. A-B-C-A-B-C... phase sequence.

Figure 19a, on the other hand, shows the same three-phase power system rotating in counterclockwise (ccw) direction. The corresponding phase sequence is A-C-B-A-C-B.... Figure 19b and Figure 19c show the resulting phase voltage waveforms and phase voltage phasor diagram, respectively.

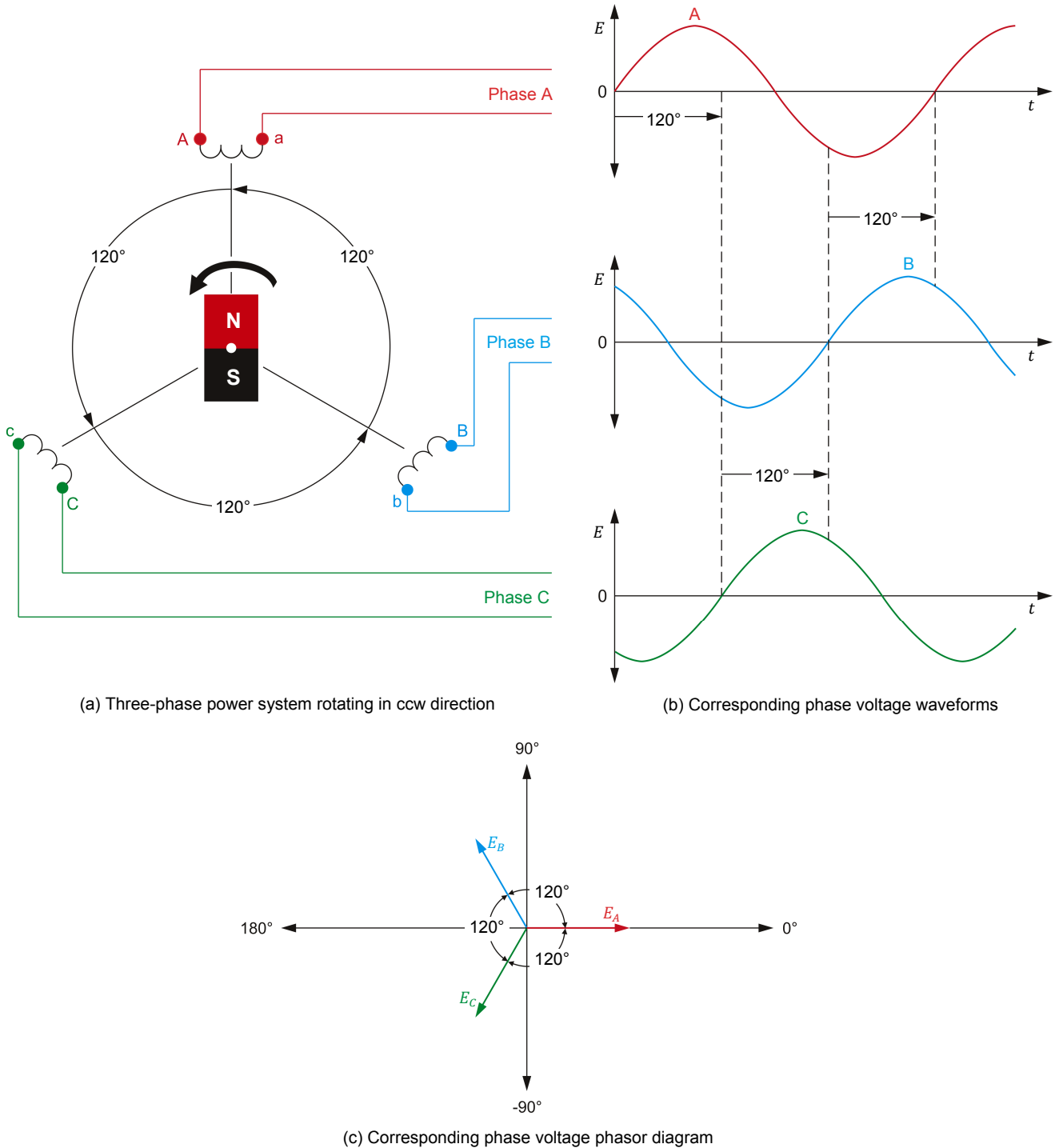

Figure 19. A-C-B-A-C-B... phase sequence.

When phase sequence A-B-C is written in the form A-B-C-A-B-C..., it becomes clear that B-C-A and C-A-B represent the same sequence as A-B-C and that only the phase used as reference for describing the sequence has changed. The opposite sequence to A-B-C is A-C-B, which is the same as C-B-A and B-A-C (as demonstrated when the sequence is written in the form A-C-B-A-C-B...). Thus, the phase sequence of a three-phase system can be inverted by simply interchanging any two phases of the system.

When connecting a three-phase motor to power lines, it is extremely important to know the phase sequence of the power distribution system because the direction in which the motor turns depends on it. Consider for example the connection of a 4000-kW three-phase motor. It takes several hours of work for an electrician to connect the three large leads of the motor to the local three-phase power system. If the phase sequence is not determined in advance, the motor has a fifty percent chance of turning in the wrong direction, which would result in the work having to be redone and possibly in damage to the equipment if the motor is connected to a load. Another situation where phase sequence is of critical importance is when additional power is needed in a three-phase ac power network, and one or more alternators (three-phase ac generators) must be added to share the load. The alternators are connected in parallel and so, if the phase sequencing is incorrect, serious damage will occur when the switch connecting the alternators to the power network is turned on.

### **Determining the phase sequence of a three-phase power system using an oscilloscope**

The phase sequence of a three-phase power system can be determined quickly by observing the power system phase voltage waveforms related to the system using an oscilloscope. Figure 20 shows an oscilloscope display obtained when channels 1, 2, and 3 of the oscilloscope are connected to phases A, B, and C, respectively, of a three-phase ac power source. In this case, the voltage waveforms of phases A, B, and C appear in sequence from top to bottom on the oscilloscope display, thereby indicating that the phase sequence with the present connections to channels 1, 2, and 3 is A-B-C.

Oscilloscope Settings  
 Channel-1 Scale .....200 V/div  
 Channel-2 Scale .....200 V/div  
 Channel-3 Scale .....200 V/div  
 Time Base..... 5 ms/div

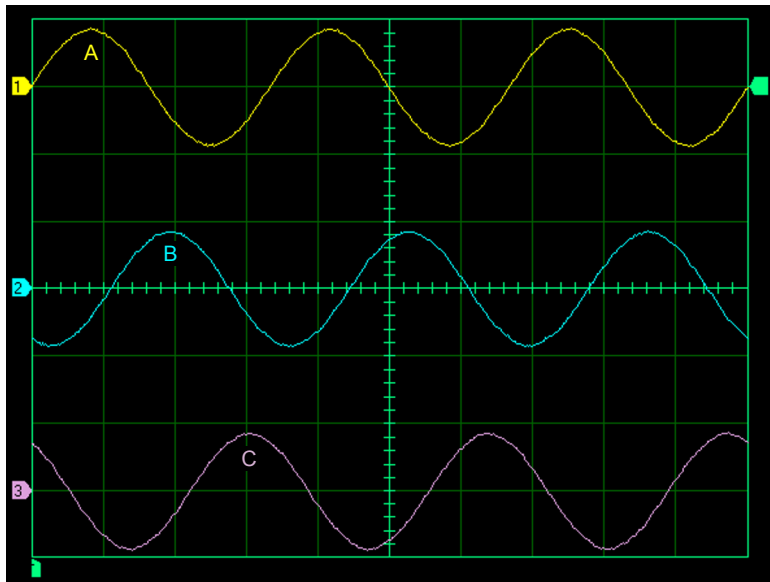

Figure 20. Oscilloscope display when channels 1, 2, and 3 of an oscilloscope are connected to phases A, B, and C, respectively, of a three-phase ac power source.

In Figure 21, the connections to phases B and C of the three-phase ac power source have been inverted and channels 1, 2, and 3 of the oscilloscope are now connected to phases A, C, and B, respectively. In this case, the voltage waveforms of phases A, C, and B appear in sequence from top to bottom on the oscilloscope display, thereby indicating that the phase sequence with the present connections to channels 1, 2, and 3 is A-C-B. Therefore, the oscilloscope display clearly shows that the phase sequence has been inverted.

Oscilloscope Settings  
 Channel-1 Scale .....200 V/div  
 Channel-2 Scale .....200 V/div  
 Channel-3 Scale .....200 V/div  
 Time Base..... 5 ms/div

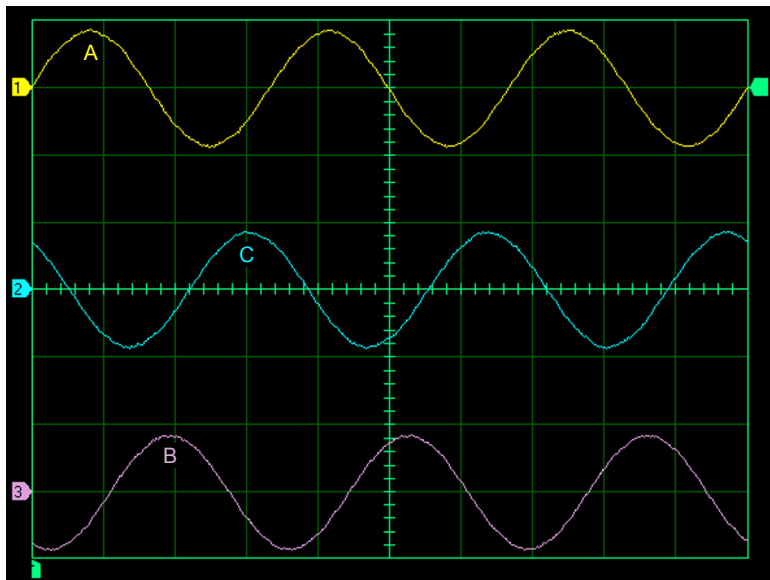

Figure 21. Oscilloscope display when channels 1, 2, and 3 of an oscilloscope are connected to phases A, C, and B, respectively, of a three-phase ac power source.



### Connecting an oscilloscope to a three-phase power system

When the neutral wire of a three-phase power system is available, each channel of the oscilloscope can be connected directly to a line wire and the neutral wire to measure a phase voltage, as shown in Figure 22.

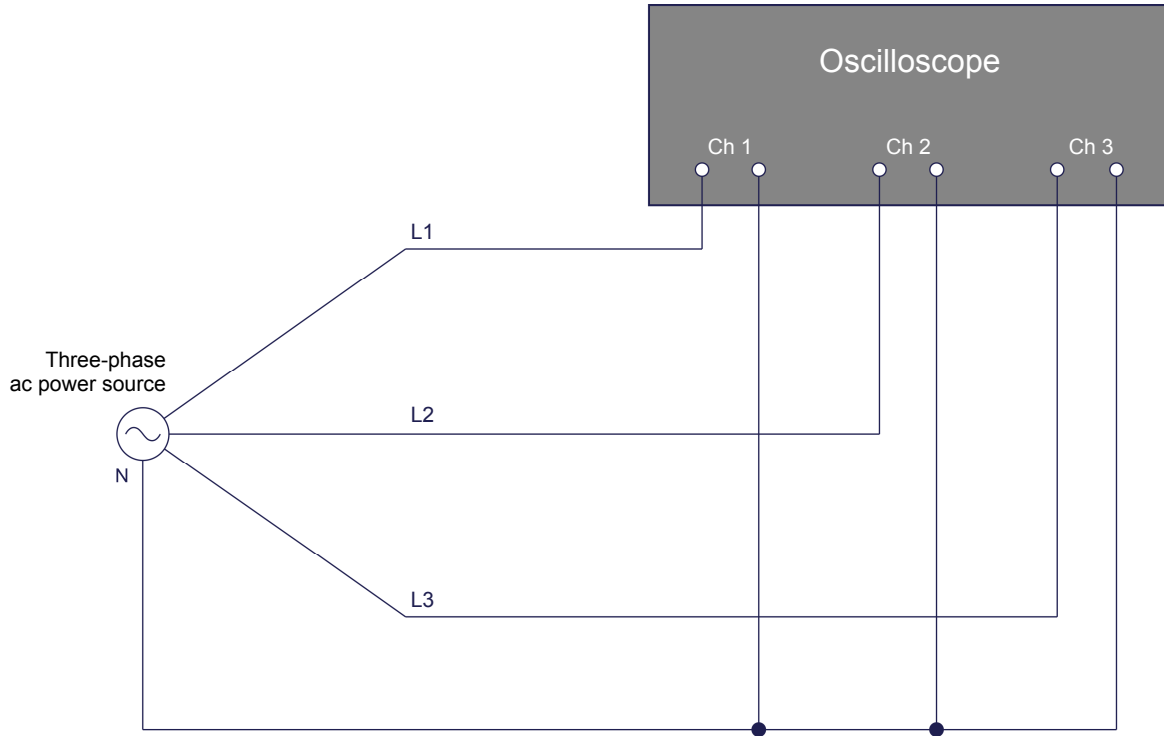

Figure 22. Oscilloscope connections to a four-wire, three-phase power system.

In most cases, direct connection of the oscilloscope to a three-wire, three-phase power system to measure the phase voltages is not possible because the neutral point generally is not available. In this case, a balanced, wye-connected resistive load is temporarily connected to the line wires of the three-phase power system and each oscilloscope channel is connected to measure the phase voltage across one of the load resistors. Figure 23 shows the circuit connections required to connect an oscilloscope to a three-wire, three-phase power system (system with no neutral wire).

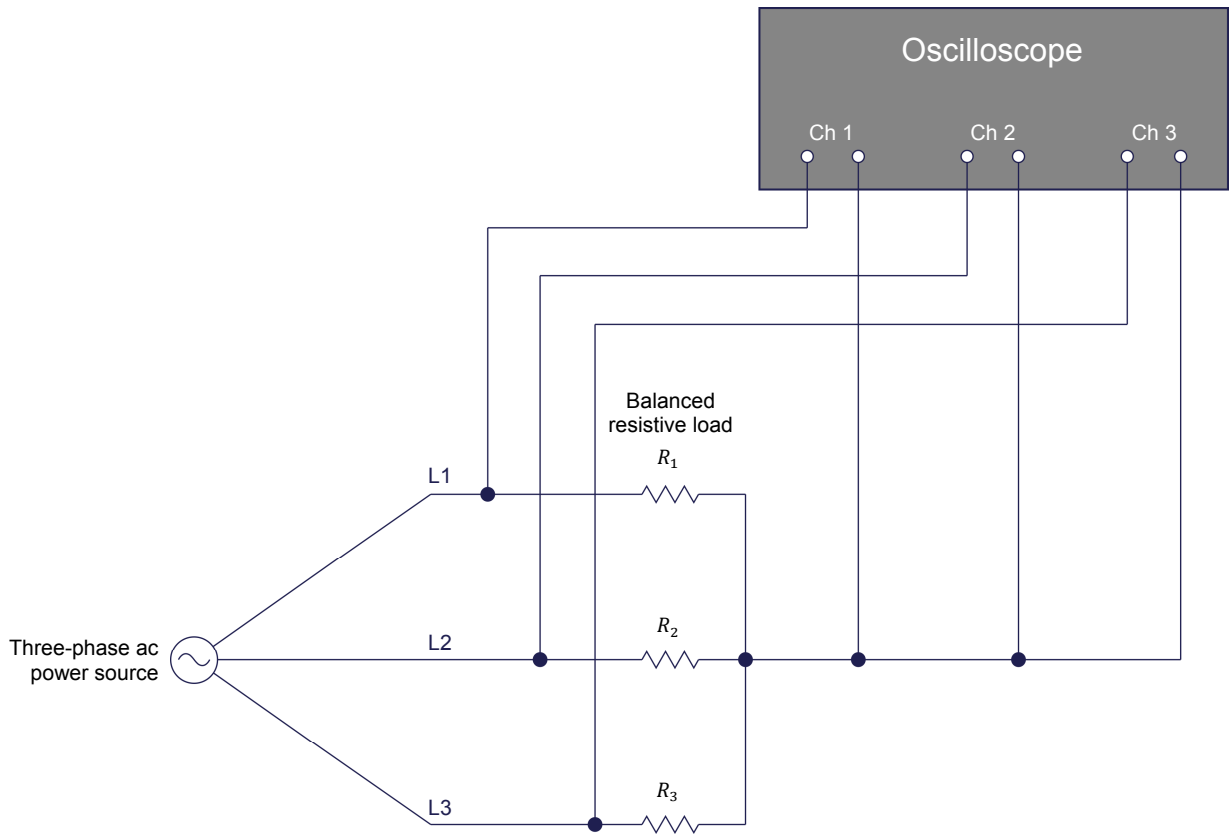

Figure 23. Oscilloscope connections to a three-wire, three-phase power system (system with no neutral wire).

## PROCEDURE OUTLINE

The Procedure is divided into the following sections:

- Setup and connections
- Determining the phase sequence of the three-phase ac power source

## PROCEDURE

### ⚠ WARNING



High voltages are present in this laboratory exercise. Do not make or modify any banana jack connections with the power on unless otherwise specified.

### Setup and connections

*In this section, you will set up the equipment to determine the phase sequence of the three-phase ac power source in the Power Supply.*

1. Refer to the Equipment Utilization Chart in Appendix A to obtain the list of equipment required to perform this exercise.

Install the required equipment in the [Workstation](#).

Make sure that the ac and dc power switches on the [Power Supply](#) are set to the **O** (off) position, then connect the [Power Supply](#) to a three-phase ac power outlet.

Connect the [Power Input](#) of the [Data Acquisition and Control Interface](#) to a 24 V ac power supply. Turn the 24 V ac power supply on.

2. Connect the USB port of the [Data Acquisition and Control Interface](#) to a USB port of the host computer.
3. Turn the host computer on, then start the [LVDAC-EMS](#) software.

In the [LVDAC-EMS Start-Up](#) window, make sure that the [Data Acquisition and Control Interface](#) is detected. Make sure that the [Computer-Based Instrumentation](#) function for the [Data Acquisition and Control Interface](#) is available. Select the network voltage and frequency that correspond to the voltage and frequency of your local ac power network, then click the **OK** button to close the [LVDAC-EMS Start-Up](#) window.

4. Set up the circuit shown in Figure 24.

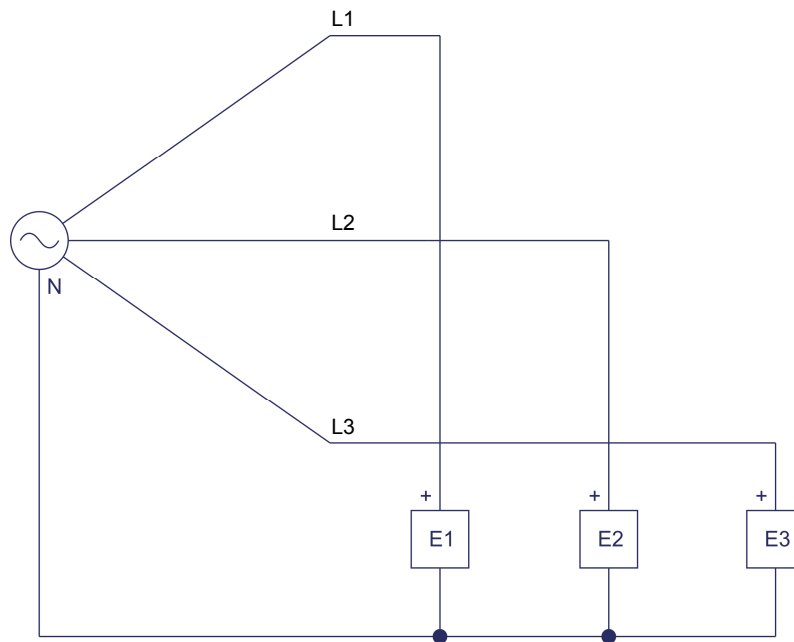

**Figure 24.** Circuit set up for determining the phase sequence of the three-phase ac power source in the [Power Supply](#).

### Determining the phase sequence of the three-phase ac power source

*In this section, you will determine the phase sequence of the three-phase ac power source in the Power Supply by observing the phase voltage waveforms using the Oscilloscope, and confirm the phase sequence by observing the phase voltage phasors using the Phasor Analyzer. You will then interchange the connections at two terminals of the three-phase ac power source and determine the new phase sequence using the Oscilloscope. Finally, you will confirm the new phase sequence using the Phasor Analyzer.*

5. Turn the three-phase ac power source in the **Power Supply** on.

In **LVDAC-EMS**, open the **Oscilloscope**, then make the appropriate settings in order to observe the phase voltage waveforms related to inputs **E1**, **E2**, and **E3**.

Using the **Oscilloscope**, determine the phase sequence of the three-phase ac power source from the phase voltage waveforms you observe.



*The phase sequence related to terminals **L1**, **L2**, and **L3** of the **Power Supply** is A-B-C. When the three-phase ac power outlet to which the **Power Supply** is connected is wired accordingly, the sequence of the phase voltages at terminals **L1**, **L2**, and **L3** is A-B-C.*

Phase sequence: \_\_\_\_\_

6. In **LVDAC-EMS**, open the **Phasor Analyzer**, then make the appropriate settings in order to observe the phasors of the phase voltages measured using inputs **E1**, **E2**, and **E3** of the **Data Acquisition and Control Interface**.
7. Using the **Phasor Analyzer**, observe the relative positions of the phase voltage phasors at terminals **L1**, **L2**, and **L3** of the three-phase ac power source (i.e., the phasors of the phase voltages measured using inputs **E1**, **E2**, and **E3**). Determine the phase sequence from the phase voltage phasors you observe.

Phase sequence: \_\_\_\_\_

Is the phase sequence the same as the phase sequence you determined in step 5?

Yes     No

8. Turn the three-phase ac power source in the **Power Supply** off, then interchange the connections at terminals **L2** and **L3** of the **Power Supply**.

Turn the three-phase ac power source in the **Power Supply** back on.

9. Using the **Oscilloscope**, determine the phase sequence of the three-phase ac power source from the phase voltage waveforms you observe and record it below.

Phase sequence: \_\_\_\_\_

Is the phase voltage sequence opposite to the one you recorded in step 5?

Yes     No

10. Using the **Phasor Analyzer**, observe the relative positions of the phase voltage phasors at terminals **L1**, **L2**, and **L3** of the three-phase ac power source (i.e., the phasors of the phase voltages measured using inputs **E1**, **E2**, and **E3**). Determine the phase sequence from the phase voltage phasors you observe.

Phase sequence: \_\_\_\_\_

Is the phase sequence the same as the phase sequence you determined in the previous step?

Yes     No

11. What is the effect on the phase sequence of the three-phase ac power source in the **Power Supply** of interchanging the connections at two terminals of the **Power Supply**?

\_\_\_\_\_  
\_\_\_\_\_

12. Close **LVDAC-EMS**, then turn off all the equipment. Disconnect all leads and return them to their storage location.

**CONCLUSION**

In this exercise, you saw what a phase sequence is and why it is important to know the phase sequence of a three-phase ac power system. You learned how to determine the phase sequence of a three-phase ac power source using an oscilloscope.

**REVIEW QUESTIONS**

1. Why is it important to know the phase sequence of a three-phase power distribution system when connecting a three-phase motor to the system?

\_\_\_\_\_  
\_\_\_\_\_  
\_\_\_\_\_

2. What is the phase sequence opposite to B-A-C?

\_\_\_\_\_

3. Determine the phase sequence of the voltage waveforms shown in the following figure.

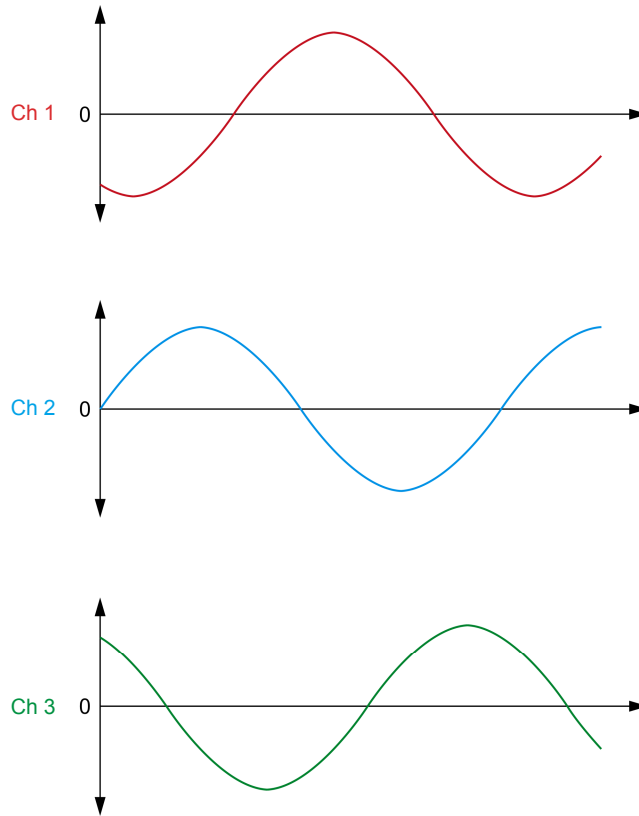

Figure 25. Voltage waveforms.

Phase sequence: \_\_\_\_\_

4. How is it possible to use an oscilloscope to determine the phase sequence of a three-wire, three-phase ac power system?

---

---

---

---

---

5. A three-phase motor rotates clockwise when lines A, B, and C of a three-phase ac power source are connected to motor leads 1, 2, and 3, respectively. If the connections are interchanged so that lines A, B, and C are now connected to leads 3, 1, and 2, respectively, determine the motor's new direction of rotation.

---

---

---

## Equipment Utilization Chart

The following equipment is required to perform the exercises in this manual.

Equipment				
Model	Description	1	2	3
8131 <sup>(1)</sup>	Workstation	1	1	1
8311 <sup>(2)</sup>	Resistive Load	1	1	1
8331	Capacitive Load		1	
8823	Power Supply	1	1	1
8951-L	Connection Leads	1	1	1
9063-B <sup>(3)</sup>	Data Acquisition and Control Interface	1	1	1
<p><sup>(1)</sup> The Mobile Workstation, Model 8110, and the Workstation, Model 8134, can also be used.</p> <p><sup>(2)</sup> Resistive Load unit with voltage rating corresponding to your local ac power network voltage. Use model variant -00, -01, -02, -05, -06, -07, or -0A.</p> <p><sup>(3)</sup> Model 9063-B consists of the Data Acquisition and Control Interface, Model 9063, with control function set 9069-1.</p>				





## Glossary of New Terms

<b>balanced three-phase circuit</b>	A balanced, three-phase circuit is a three-phase ac circuit with equal impedances in each of the three load branches. The three phase voltages that power the circuit are equal in amplitude, but are shifted $120^\circ$ from each other. A balanced, three-phase circuit is thus simply a combination of three single-phase circuits. Therefore, the rules for calculating voltage, current, and power in single-phase circuits also apply to balanced three-phase circuits.
<b>delta configuration</b>	A delta configuration is a type of three-phase circuit connection in which the three branches of the source or load are connected end-to-end to form a continuous (closed) circuit loop. The three line wires are connected to the three junction points of the circuit. There is no point to which a neutral wire can be connected in a delta-connected, three-phase circuit.
<b>line current</b>	The line current in a three-phase circuit is the current measured in any line wire of the circuit. In balanced, delta-connected, three-phase circuits, the line current is $\sqrt{3}$ times higher than the phase current.
<b>line voltage</b>	The line voltage in a three-phase circuit is the voltage measured between any two line wires of the circuit. In balanced, wye-connected, three-phase circuits, the line voltage is $\sqrt{3}$ times higher than the phase voltage.
<b>phase current</b>	The phase current in a three-phase circuit is the current measured in any phase of the circuit (i.e., the current flowing in each element of a three-phase load). In balanced, delta-connected, three-phase circuits, the phase current is $\sqrt{3}$ times lower than the line current.
<b>phase sequence</b>	The phase sequence of a three-phase ac power system is the sequence in which the phase voltages attain the maximum (peak) value. The usual shorthand form of indicating phase sequence is A-B-C, which is the same as the sequences B-C-A and C-A-B. The opposite phase sequence to A-B-C is A-C-B (C-B-A, B-A-C).
<b>phase voltage</b>	The phase voltage in a three-phase circuit is the voltage measured between any line wire and the neutral wire of the circuit. In balanced, wye-connected, three-phase circuits, the phase voltage is $\sqrt{3}$ times lower than the line voltage.
<b>two-wattmeter method</b>	The two-wattmeter method is a method of measuring power in three-phase circuits in which two single-phase power meters are connected across the line wires so that the total power is the algebraic sum of the two power meter readings. When using this method, the two current inputs of the power meters are connected to measure the line current in two of the line wires while the two voltage inputs of the power meters are connected to measure the line voltages between the two line wires connected to the current inputs and the remaining line wire. The two-wattmeter method allows power in three-wire, three-phase power systems to be measured as it uses line voltage and current measurements only.

**wye configuration**

A wye configuration is a type of three-phase circuit connection in which one end of each of the three branches of the source or load are connected together at a common junction point called the neutral. The three line wires are each connected to an individual circuit branch, and a neutral wire can be connected to the neutral point of the circuit. In a balanced three-phase circuit, no current flows in the neutral wire.

## Impedance Table for the Load Modules

The following table gives impedance values which can be obtained using either the Resistive Load, Model 8311, the Inductive Load, Model 8321, or the Capacitive Load, Model 8331. Figure 26 shows the load elements and connections. Other parallel combinations can be used to obtain the same impedance values listed.

Table 4. Impedance table for the load modules.

Impedance ( $\Omega$ )			Position of the switches								
120 V 60 Hz	220 V 50 Hz/60 Hz	240 V 50 Hz	1	2	3	4	5	6	7	8	9
1200	4400	4800									
600	2200	2400									
300	1100	1200									
400	1467	1600									
240	880	960									
200	733	800									
171	629	686									
150	550	600									
133	489	533									
120	440	480									
109	400	436									
100	367	400									
92	338	369									
86	314	343									
80	293	320									
75	275	300									
71	259	282									
67	244	267									
63	232	253									
60	220	240									
57	210	229									

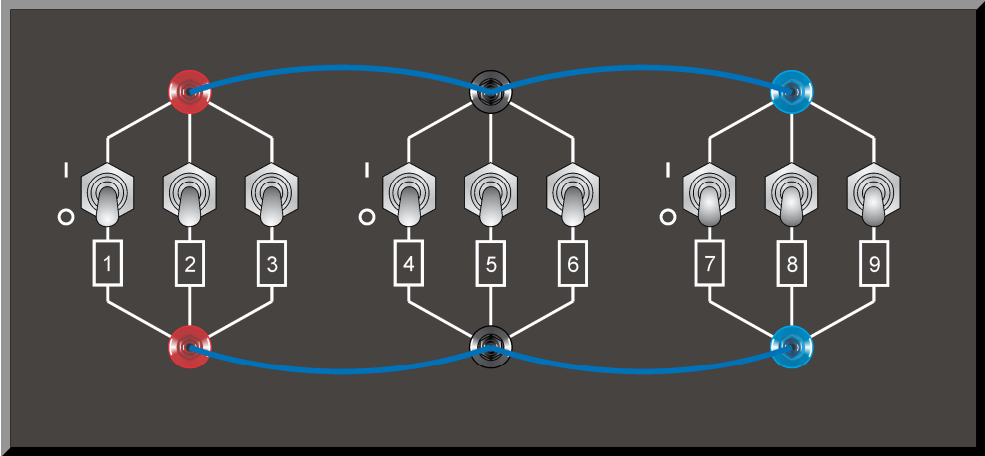
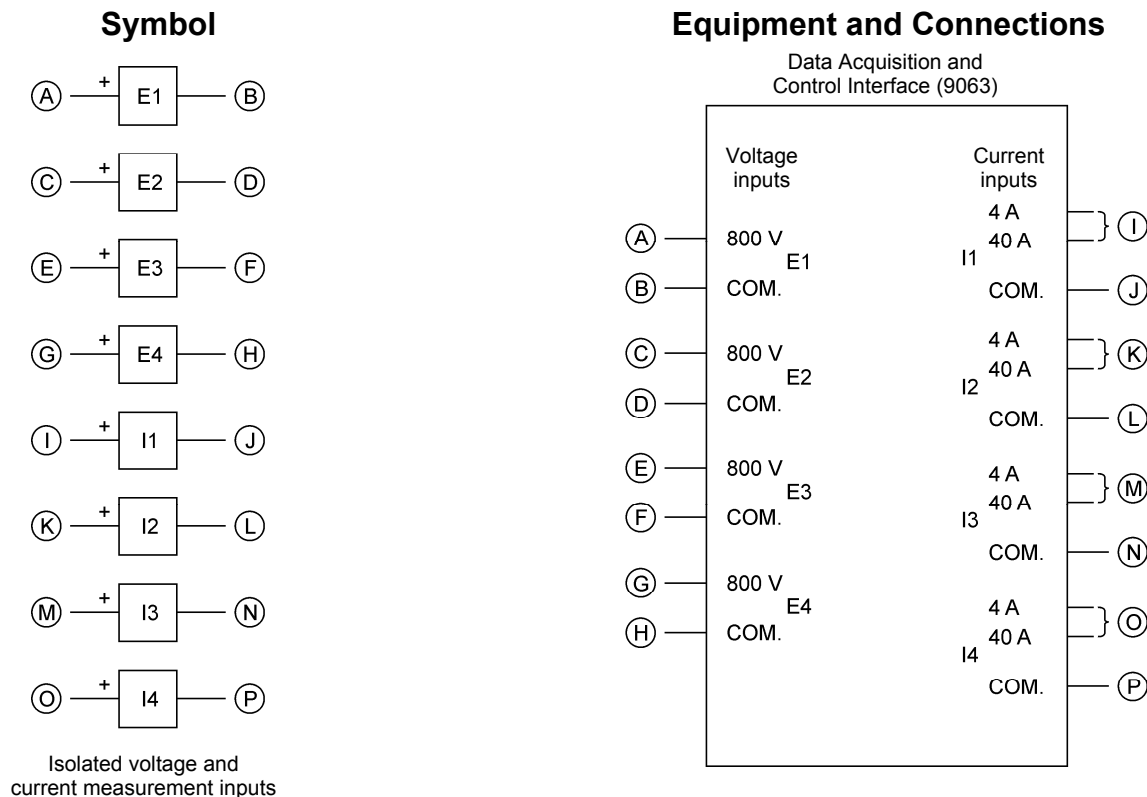

Figure 26. Location of the load elements on the Resistive Load, Inductive Load, and Capacitive Load, Models 8311, 8321, and 8331, respectively.

## Circuit Diagram Symbols

Various symbols are used in the circuit diagrams of this manual. Each symbol is a functional representation of a particular electrical device that can be implemented using the equipment. The use of these symbols greatly simplifies the number of interconnections that need to be shown on the circuit diagram, and thus, makes it easier to understand the circuit operation.

For each symbol other than those of power sources, resistors, inductors, and capacitors, this appendix gives the name of the device which the symbol represents, as well as the equipment and the connections required to properly connect the device to a circuit. Notice that the terminals of each symbol are identified using circled letters. The same circled letters identify the corresponding terminals in the Equipment and Connections diagram. Also notice that the numbers (when present) in the Equipment and Connections diagrams correspond to terminal numbering used on the actual equipment.



When a current at inputs I1, I2, I3, or I4 exceeds 4 A (either permanently or momentarily), use the corresponding 40 A input terminal and set the Range parameter of the corresponding input to High in the Data Acquisition and Control Settings window of LVDAC-EMS.

**Symbol**

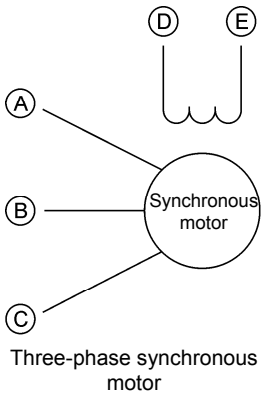
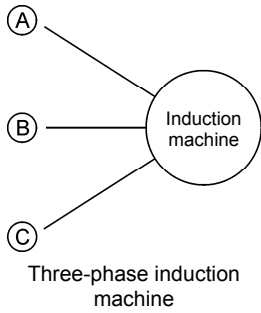
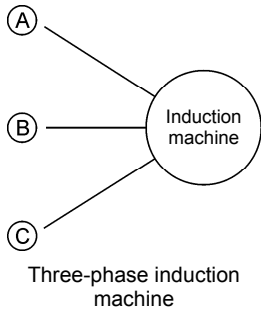

**Equipment and Connections**

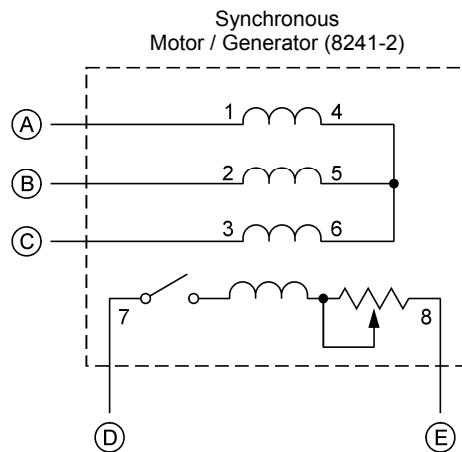
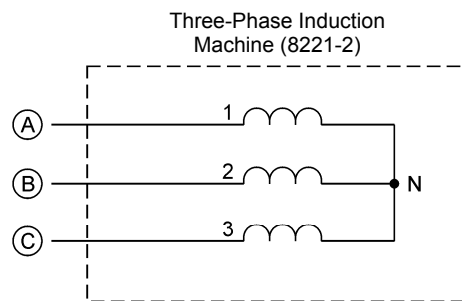
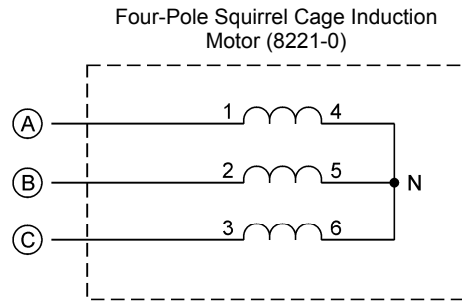

**Symbol**

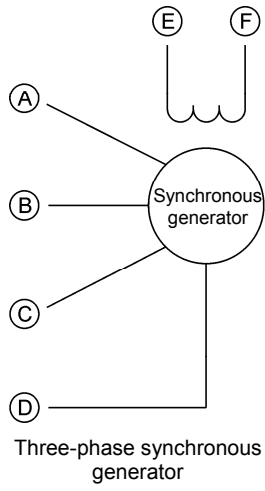

**Equipment and Connections**

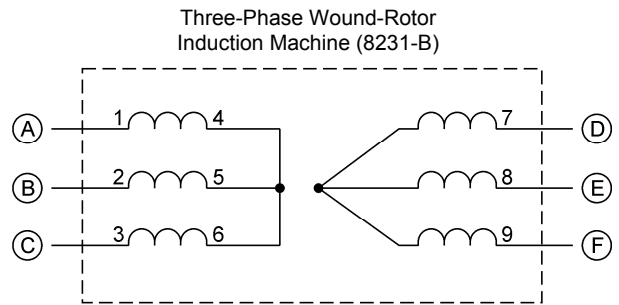
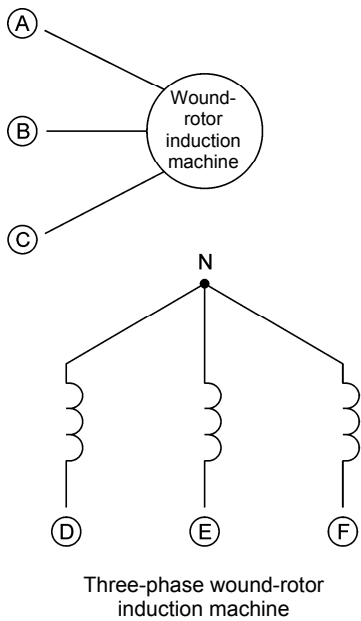
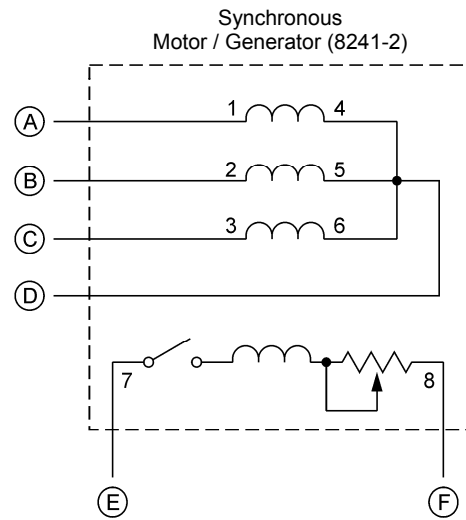



**Symbol**

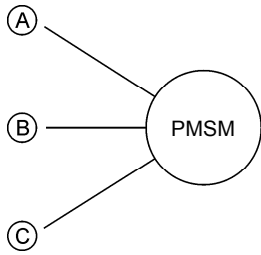

Permanent Magnet Synchronous Machine

**Equipment and Connections**

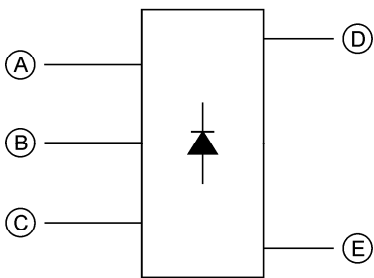
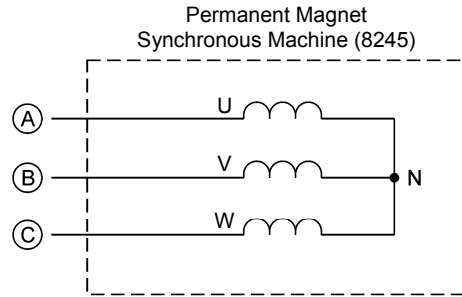

Power diode three-phase full-wave rectifier

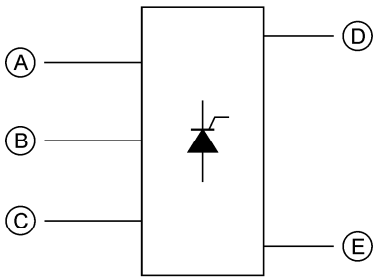
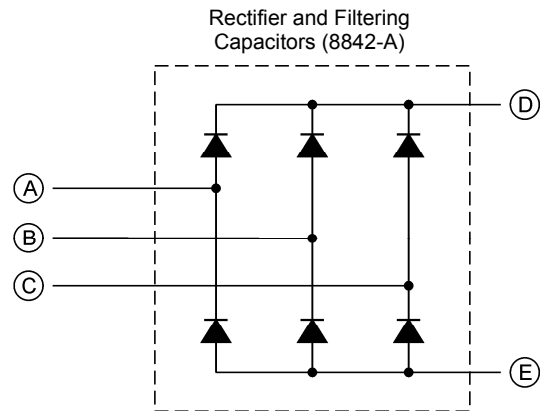

Power thyristor three-phase bridge

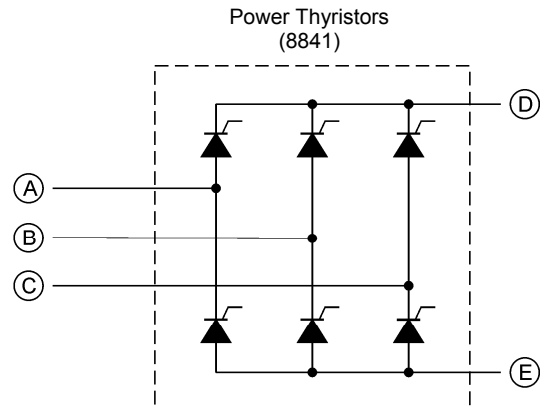

**Symbol**

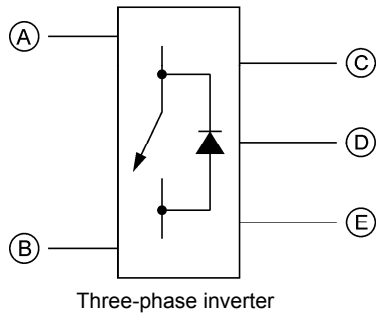

**Equipment and Connections**

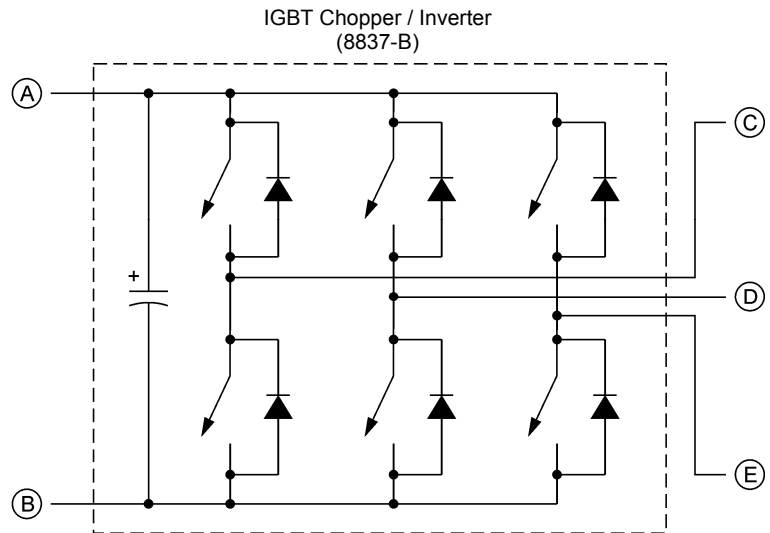



# Index of New Terms



*The bold page number indicates the main entry. Refer to the Glossary of New Terms above for definitions of new terms.*

balanced three-phase circuit.....	<b>1</b> , 20
delta configuration.....	<b>3</b> , 5, 23
line current .....	<b>5</b> , 19, 20
line voltage .....	<b>4</b> , 5, 20
phase current .....	<b>5</b> , 19
phase sequence.....	<b>2</b> , 41, 43, 44, 45, 47
phase voltage.....	<b>4</b> , 5, 20, 41, 43, 44, 46
two-wattmeter method .....	<b>24</b> , 25
wye configuration .....	<b>3</b> , 5, 22



# Bibliography

Boylestad, Robert L., *Introductory Circuit Analysis*, 11<sup>th</sup> Edition, Upper Saddle River, Prentice Hall, 2006, ISBN 978-0131730441.

Wildi, Theodore, *Electrical Machines, Drives, and Power Systems*, 6<sup>th</sup> Edition, Upper Saddle River, Prentice Hall, 2005, ISBN 978-0131776913.